

Installation Instructions

Refrigerator

Questions? Visit our Website at: cafeappliances.com
 In Canada, visit cafeappliances.ca

BEFORE YOU BEGIN

Read these instructions completely and carefully.

- **IMPORTANT** — Observe all governing codes and ordinances. Save these instructions for local inspector's use.
- **Note to Installer** – Be sure to leave these instructions with the Consumer.
- **Note to Consumer** – Keep these instructions for future reference.
- **Skill level** – Installation of this appliance requires basic mechanical skills.
- **Completion time** – Refrigerator Installation
20 minutes
Water Line Installation
30 minutes
- Proper installation is the responsibility of the installer.
- Product failure due to improper installation is not covered under the Warranty.

PREPARATION

MOVING THE REFRIGERATOR INDOORS

If the refrigerator will not fit through a doorway, the refrigerator door and freezer drawer or door can be removed.

- To remove the refrigerator doors, see Removing French Doors section.
- To remove the freezer drawer, see the Removing the Freezer Drawer section.

WATER SUPPLY TO THE ICEMAKER AND DISPENSER

If the refrigerator has an icemaker, it will have to be connected to a cold water line. A Café water supply kit (containing tubing, shutoff valve, fittings and instructions) is available at extra cost from your dealer, or by visiting our website at cafeappliances.com/parts. In Canada, visit cafeappliances.ca/parts.

TOOLS YOU MAY NEED



Adjustable Wrench

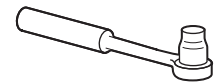

3/8" and 5/8" Socket Ratchet/Driver



1/4" Outer Diameter Compression Nut and Ferrule (sleeve) (icemaker models only)

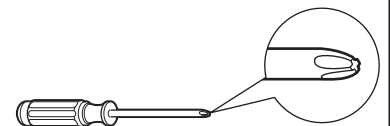

Phillips-Head Screwdriver



3/32", 1/8" & 3/16" Allen Wrenches

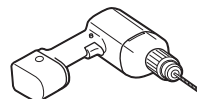

1/8" Drill Bit and Electric or Hand Drill

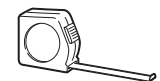

Tape Measure



Pencil



1/4" Nut Driver



Wire Cutters



Level

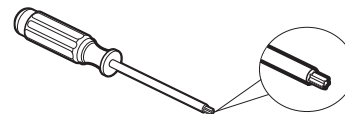

Torx T20, Driver

Installation Instructions

APPLIANCE DIMENSIONS

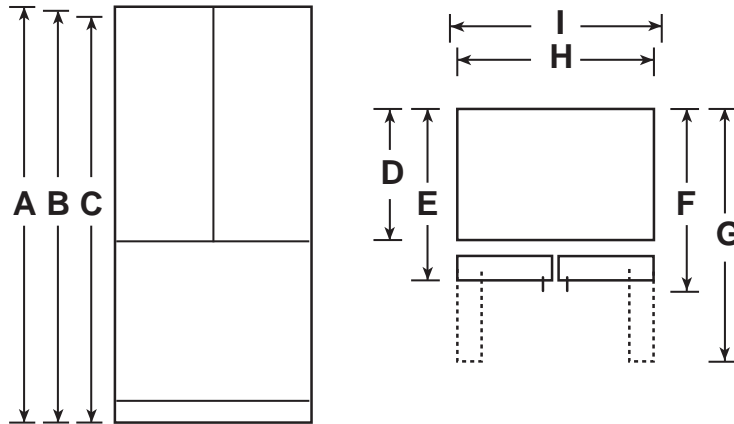

		CWE19S	CFE26K
OVERALL DIMENSIONS	Height to top of door (in.) A	69-7/8	69-7/8
	Height to top of hinge (in.) B	69-3/4	69-3/4
	Height to top of case (in.) C	68-5/8	68-5/8
	Case depth without door (in.) D	24-1/8	29-1/2
	Case depth less door handle (in.) E	29	33-7/8
	Case depth with door handle (in.) F	31-1/8	36-7/16
	Depth with refrigerator door open 90° (in.) G	42	48-3/4
	Width (in.) H	32-3/4	35-5/8
	Width with door open 90 inc. door handle (in.) I	41	43-13/16

MEASURE THE CABINET OPENING ACCORDING TO THE WIDTH OF THE REFRIGERATOR

Measure width of cabinet opening where refrigerator will be placed, B. Be sure to account for any countertop overhang, baseboard thickness and any clearance desired. Width, B, should not be less than 33"-36" (83.3 cm - 91.4 cm) (depending on model). The refrigerator will be placed approximately in the middle of this opening.

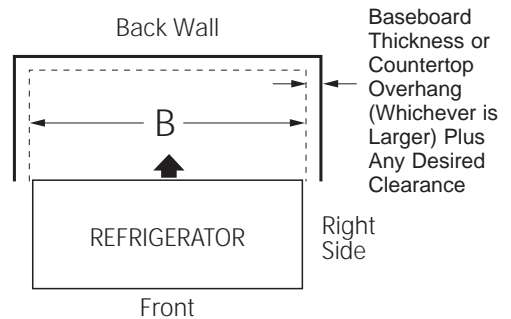

Installation Instructions

INSTALLING THE REFRIGERATOR

REFRIGERATOR LOCATION

- Do not install the refrigerator where the temperature will go below 60°F (16°C) because it will not run often enough to maintain proper temperatures.
- Do not install the refrigerator where the temperature will go above 100°F (37°C) because it will not perform properly.
- Do not install the refrigerator in a location exposed to water (rain, etc.) or direct sunlight.
- Install it on a floor strong enough to support it fully loaded.

CLEARANCES

Allow the following clearances for ease of installation, proper air circulation and plumbing and electrical connections.

Sides	1/8" (3 mm)	
Top	1" (25 mm)	Cabinet/Hinge Cover
Back	2" (50 mm)	

IMPORTANT NOTES

This refrigerator without the handles ranges from 33-7/8" to 35-1/4" (86 cm - 89 cm) depending on your model (see dimension E on the previous page). Doors and passageways leading to the installation location must be at least 36" (91.4 cm) in order to leave the doors attached to the refrigerator while transporting it into the installation location. If passageways are less than 36" (91.4 cm), the refrigerator doors can easily be scratched and damaged. The doors can be removed to allow the refrigerator to be safely moved indoors.

- If you need to remove the door, see Removing French Doors.
- To remove the freezer door, see Removing Freezer Drawer.
- If it is **NOT** necessary to remove doors, leave tape and all packaging on doors until the refrigerator is in the final location. Once in place, install door handles (see Steps 1 and 2).
- **SKID REMOVAL:** Tilt refrigerator to each side to remove skid.
- **NOTE:** Use a padded hand truck to move this refrigerator. Place the refrigerator on the hand truck with a side against the truck. We strongly recommend that **TWO PEOPLE** move and complete this installation.

1 ATTACH REFRIGERATOR HANDLES

1. Loosen the set screws in the handle with the 1/8" Allen wrench.
2. Place handle over mounting fasteners.
3. Tighten set screws.

Follow the same procedure for both doors.

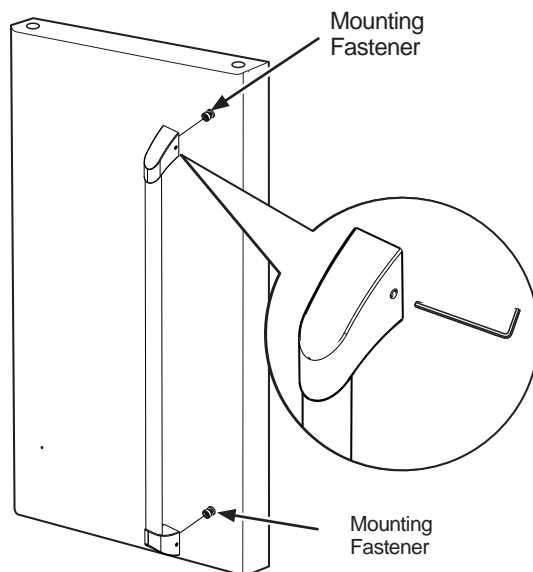

2 ATTACH FREEZER HANDLE

1. Loosen the set screws in the handle with the 1/8" Allen wrench.
2. Place handle over mounting fasteners.
3. Tighten set screws.

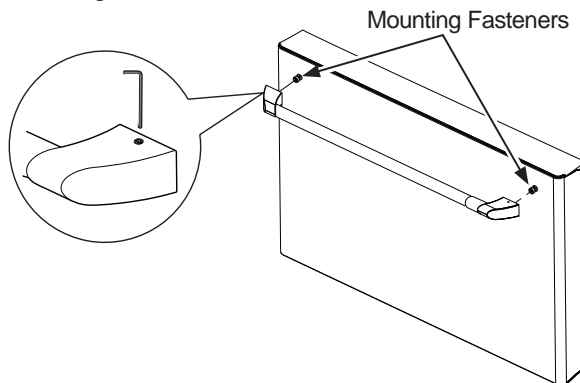

Installation Instructions

INSTALLING THE REFRIGERATOR (Cont.)

REMOVING FRENCH DOORS

IMPORTANT NOTES

When removing french doors:

- Read the instructions all the way through before starting.
- Handles are included inside the refrigerator.
- Place the screws by their related parts to avoid using them in the wrong places.
- Provide a non-scratching work surface for the doors.

CAUTION Lifting Hazard.

Single person lift can cause injury. Use assistance when handling, moving or lifting the refrigerator doors.

NOTE: When moving door, to prevent damage to door and electronics carefully place the door in a proper location.

WARNING

To eliminate the risk of electric shock or injury during installation, you must first unplug the refrigerator before proceeding. Failure to follow these instructions can result in electrical shock.

Tape the doors shut with adhesive tape.

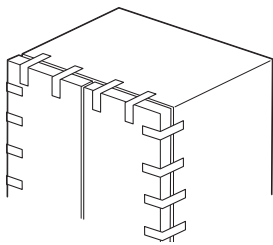

1 REMOVING RIGHT DOOR

- A. Remove the hinge cover on top of the right refrigerator door by removing the screw using a Phillips screwdriver.

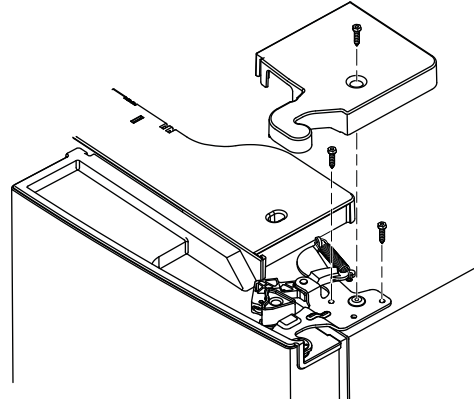

- B. Using a 5/16" socket ratchet/driver, remove the bolts securing the top hinge to the cabinet. Lift the hinge support straight up to free the hinge pin from the socket in the top of the door.
- C. Remove the tape from the right door and tilt the door away from the cabinet. Lift the door off the center hinge pin.
- D. Set the door on a non-scratching surface with the inside up.

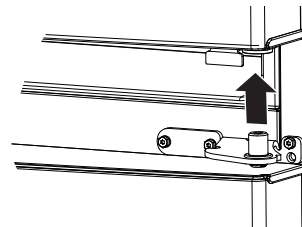

2 REMOVING LEFT DOOR

- A. **For Ice and Water Models Only:** Unplug the water line from the back of the refrigerator and remove all tape that fixes the water line to the refrigerator.

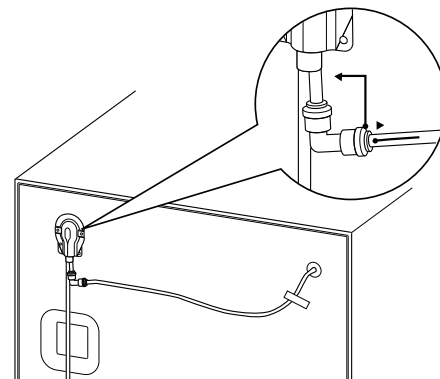

Installation Instructions

INSTALLING THE REFRIGERATOR (Cont.)

2 REMOVING LEFT DOOR (cont.)

B. Remove the hinge cover on top of the left refrigerator door by removing the screw using a Phillips screwdriver.

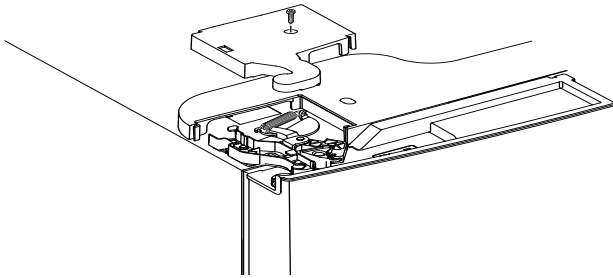

C. Unplug the 3 wire connectors and move the wires until you can see the screws holding the hinge.

For Ice and Water Models Only: Pull the water line very carefully.

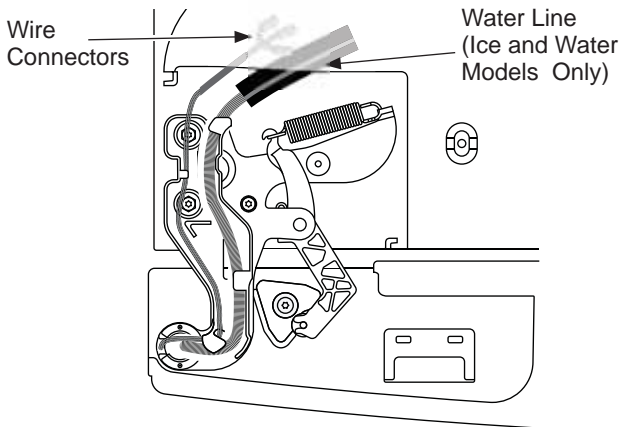

D. Using a 5/16" socket/ratchet driver, remove the bolts securing the top hinge to the cabinet.

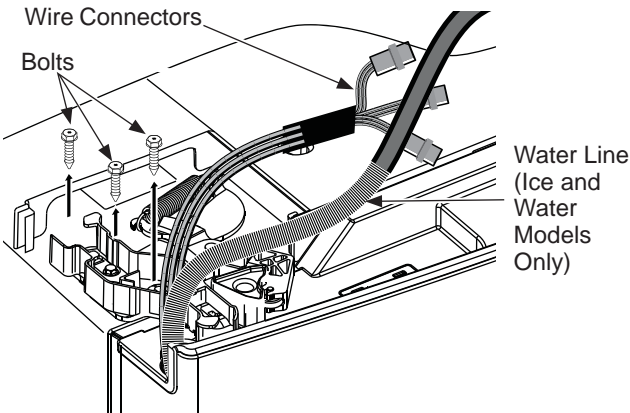

For NON Ice and Water Models Only: Lift the hinge straight up to free the hinge pin from the socket in the top of the door and pass the wire through the slot in the hinge. **For Ice and Water Models Only:** Do not remove hinge from the door.

E. Remove the tape from the door, open the door 90 degrees and tilt the door away from the cabinet. Lift the door off the center hinge pin.

F. Set the door on a non-scratching surface with the inside up.

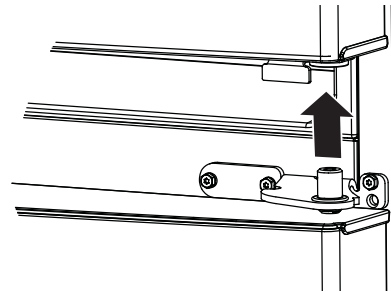

3 REMOVING CENTER HINGES AND BRACKETS

A. Using a 1/4" Allen wrench, remove the 2 hinge pins from the hinge brackets.

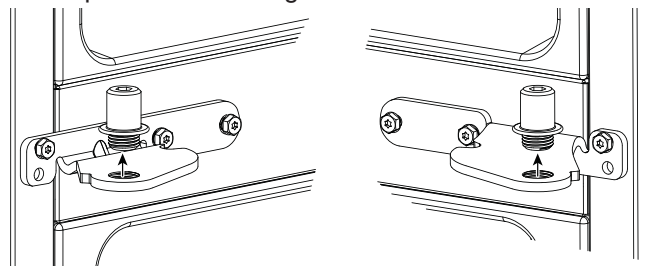

B. Using a 5/16" socket/ratchet driver, remove the bolts securing the center hinge brackets to the cabinet.

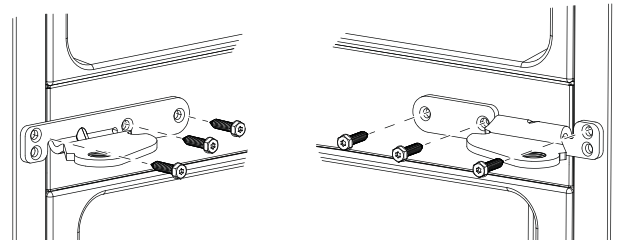

Installation Instructions

INSTALLING THE REFRIGERATOR (Cont.)

REINSTALLING FRENCH DOORS

IMPORTANT NOTES

When replacing the french doors:

- Read the instructions all the way through before starting.

⚠ CAUTION Lifting Hazard.

Single person lift can cause injury. Use assistance when handling, moving or lifting the refrigerator doors.

NOTE: When moving door, to prevent damage to door and electronics carefully place the door in a proper location.

⚠ WARNING

To eliminate the risk of electric shock or injury during installation, you must first unplug the refrigerator before proceeding. Failure to follow these instructions can result in electrical shock.

1 REINSTALLING CENTER HINGE BRACKETS AND HINGES

- A. Using a 5/16" socket/ratchet driver, reinstall the bolts and center hinge brackets to the cabinet.

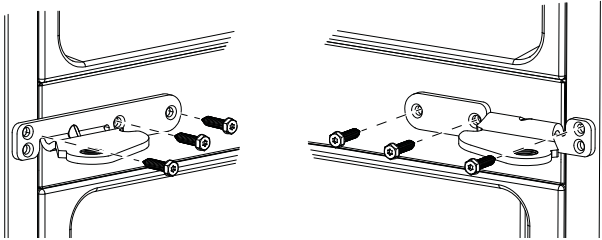

- B. Using a 1/4" Allen wrench, reinstall the 2 hinge pins into the hinge brackets.

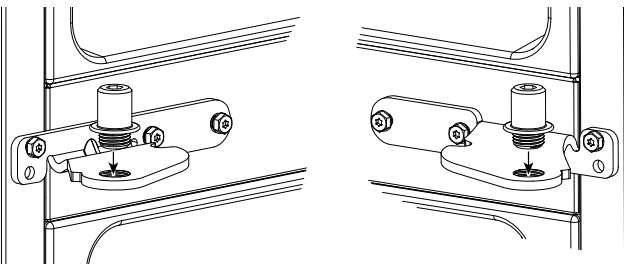

2 REHANGING THE RIGHT DOOR

- A. Lower the refrigerator door onto the right hinge pin.

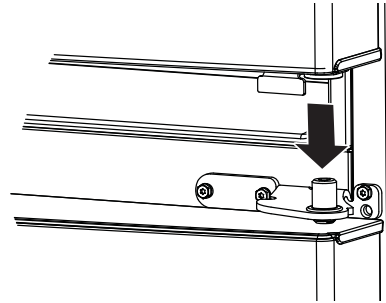

- B. Make sure the door is aligned with the cabinet. Attach the hinge to the top of the cabinet loosely with bolts removed earlier.
- C. Make sure the gasket on the door is flush against the cabinet and is not folded. Tighten the bolts to 60 lb/in. (6.78 Nm).

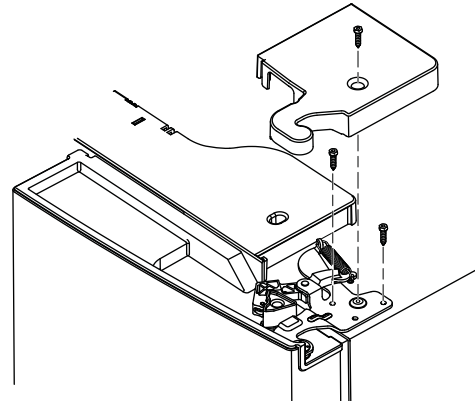

- D. Replace the right hinge cover on top of the refrigerator using a Phillips screwdriver.

3 REHANGING THE LEFT DOOR

- A. **For NON Ice and Water Models Only:** Pass the wire through the slot in the hinge. Place the hinge pin into the top of the door.
- B. Lower the refrigerator door onto the left hinge pin.

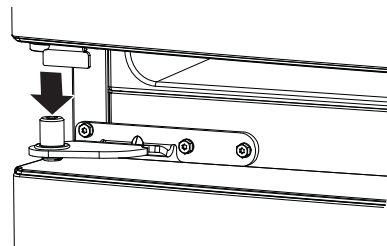

Installation Instructions

INSTALLING THE REFRIGERATOR (Cont.)

REINSTALLING FRENCH DOORS (Cont.)

③ REHANGING THE LEFT DOOR (Cont.)

- C. Make sure the door is aligned with the cabinet. Attach the hinge to the top of the cabinet loosely with bolts removed earlier.
- D. Make sure the gasket on the door is flush against the cabinet and is not folded. Tighten the bolts to 60 lb/in. (6.78 Nm).

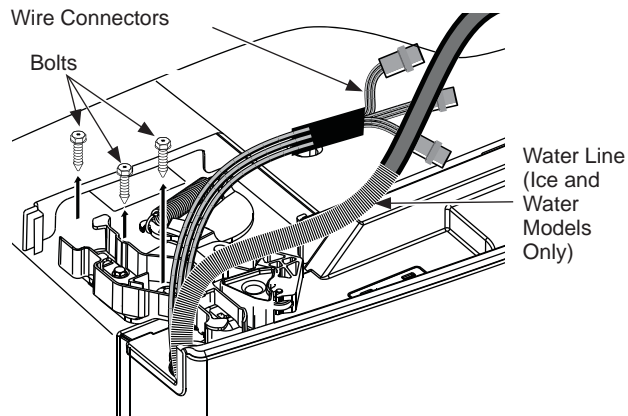

- E. Plug the wire connectors together and route the wire inside the plastic port.

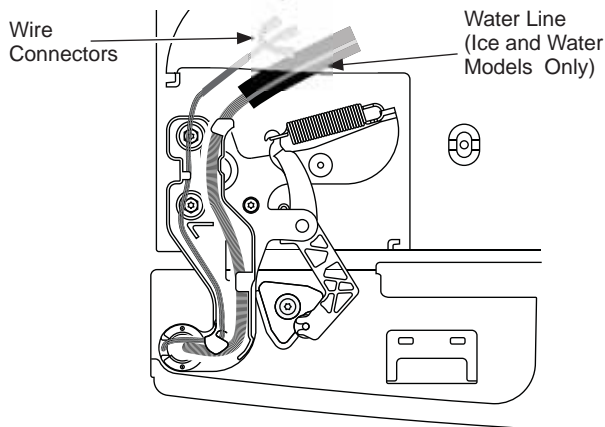

- F. **For Ice and Water Models Only:** Put the water line into the hole and pass through the plastic port to the back of the refrigerator. Plug the water line back into the fixture on back of the refrigerator. Tape water line to the refrigerator.

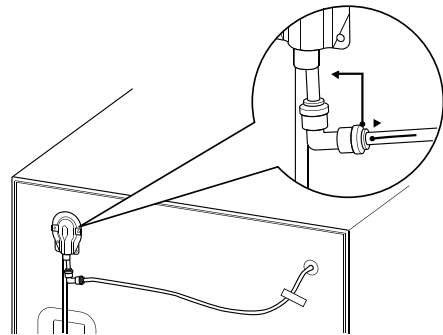

- G. Replace the left hinge cover on top of the refrigerator using a Phillips screwdriver.

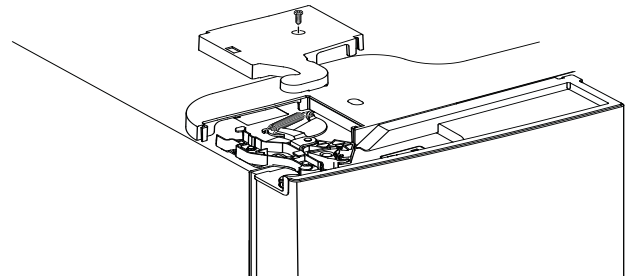

Installation Instructions

INSTALLING THE REFRIGERATOR (Cont.)

REMOVING FREEZER DRAWER

IMPORTANT NOTES

When removing freezer drawer:

- Read the instructions all the way through before starting.
- Provide a non-scratching work surface for the doors.

1 REMOVE THE BASKETS

- Open the freezer drawer until it stops.
- Pull the top basket out until it stops. Lift the basket up on the front and out to remove.

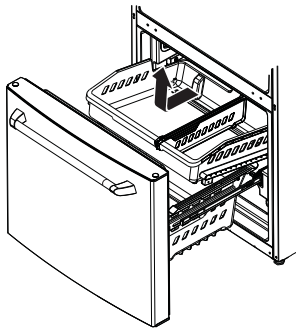

- The lower basket rests on a frame inside the freezer drawer. Lift the front of the basket and pull it forward. Release the pins from the slots on the frame to remove the basket.

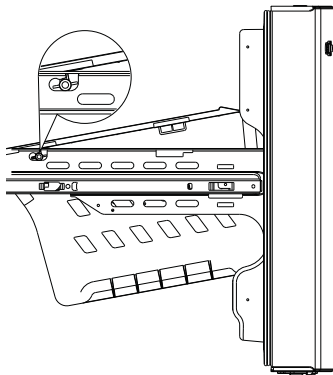

2 REMOVE THE DRAWER FRONT

- Remove the screw on each side of the railing.

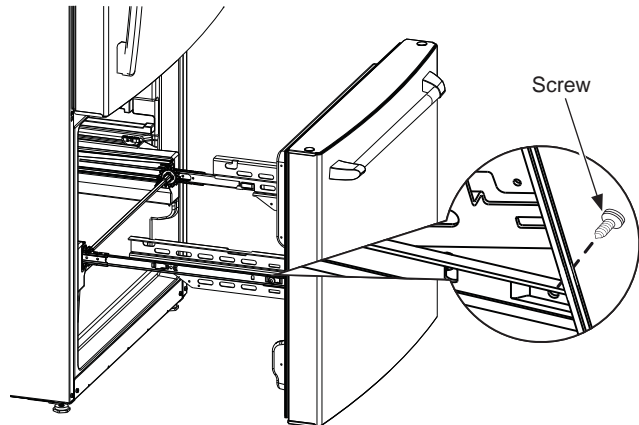

- Lift up on both sides of the freezer drawer handle to separate the drawer railings from the rail assemblies.

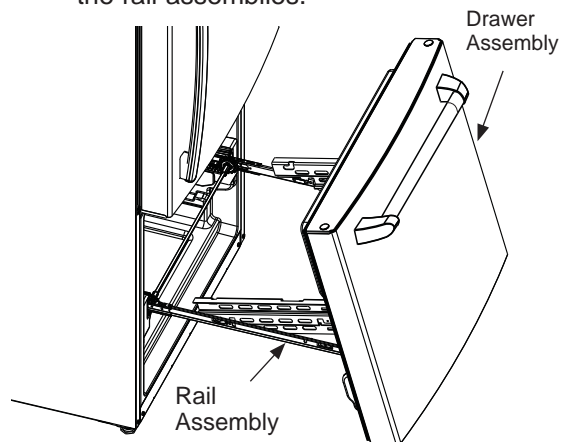

- Set the drawer front on a non-scratching surface.
- Push the rail assemblies back into locking position.

Installation Instructions

INSTALLING THE REFRIGERATOR (Cont.)

3 REINSTALL FREEZER DRAWER FRONT

- A. Pull the rail assemblies to the maximum extension.
- B. Locate the slots on the inside of each slide.

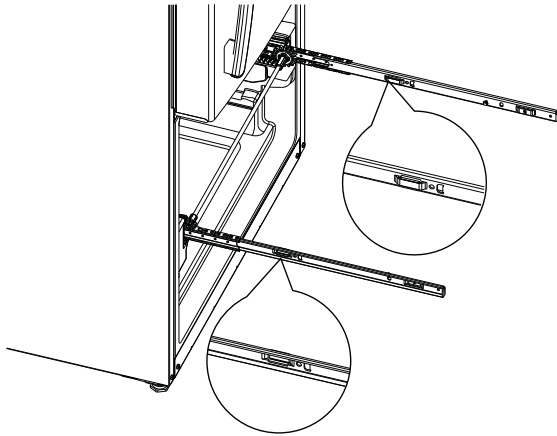

- D. Lower the front end of the freezer drawer assembly so the side tabs fit into the front slots on the rail assemblies.
- E. Replace the safety screws in both sides of the slide assemblies.

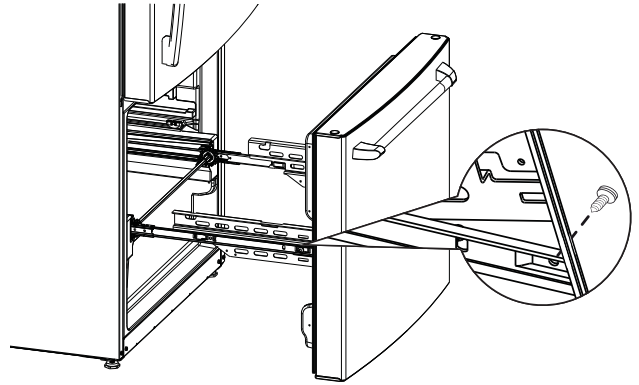

- C. Insert the hooks on the ends of the drawer assembly extensions into the slots near the back of the slides.

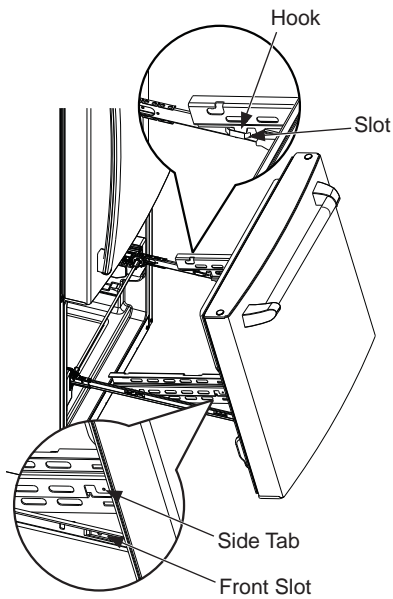

- F. Replace lower and upper baskets (see About freezer drawer, page 16).

Installation Instructions

INSTALLING THE REFRIGERATOR (Cont.)

⚠ WARNING

Connect to potable water supply only. A cold water supply is required for automatic icemaker operation. The water pressure must be between 40 and 120 psi (275-827 kilopascals).

⚠ WARNING



ELECTRIC SHOCK HAZARD

Attach tubing clamp using existing hole only. DO NOT drill into the refrigerator.

CONNECT THE TUBING TO THE REFRIGERATOR (icemaker and dispenser models)

NOTES:

- Before making the connection to the refrigerator, be sure the refrigerator power cord is not plugged into the wall outlet.
- Before connecting the water line to the house, purge the house line for at least 2 minutes.
- Some models have the refrigerator connection at the water valve (**Configuration 1**). Other models have the refrigerator connection at the end of tubing located outside the compressor compartment access cover (**Configuration 2**).
- On Configuration 1 Models, the refrigeration connection is at the water valve, remove the plastic flexible cap, as shown here.

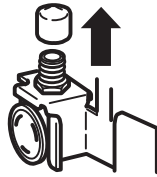

Water supply connection.

If you are using copper tubing, place a compression nut and ferrule (sleeve) onto the end of the tubing coming from the house cold water supply.

If you are using Universal water line tubing, the nuts are already assembled to the tubing.

Refrigerator Connection.

If you are using copper tubing, insert the end of the tubing into the refrigerator connection, at the back of the refrigerator, as far as possible. While holding the tubing, tighten the fitting.

If you are using Universal water line tubing, insert the molded end of the tubing into the refrigerator connection, at the back of the refrigerator, and tighten the compression nut until it is hand tight. Then tighten one additional turn with a wrench. Overtightening may cause leaks.

Refrigerator Connection Using the Tubing Clamp

Fasten the tubing into the clamp provided to hold it in position. You may need to pry open the clamp.

One of the Configurations below will look like the connection on your refrigerator.

Configuration 1

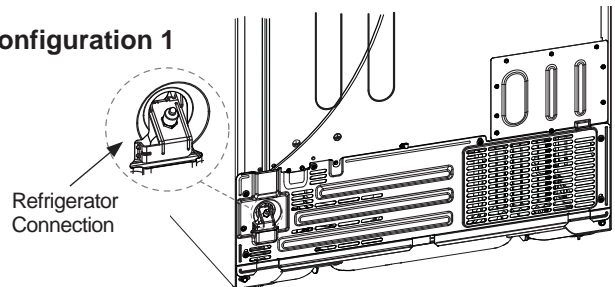

Configuration 2

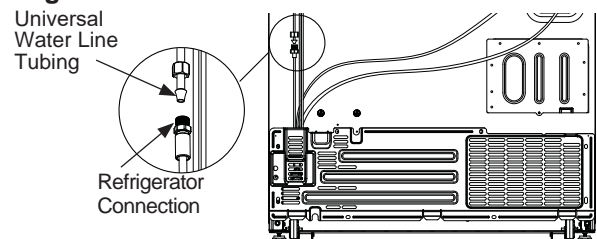

TURN ON THE WATER SUPPLY (Icemaker models only)

Turn the water on at the shutoff valve (house water supply) and check for any leaks.

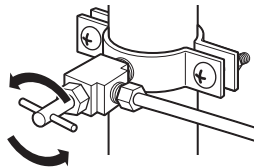

PLUG IN THE REFRIGERATOR

Arrange the coil of tubing so that it does not vibrate against the back of the refrigerator or against the wall. Push the refrigerator back to the wall.

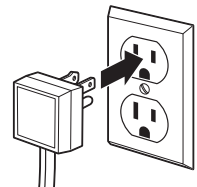

Installation Instructions

INSTALLING THE REFRIGERATOR (Cont.)

TURN ON THE WATER SUPPLY

(Icemaker models only)

Turn the water on at the shutoff valve (house water supply) and check for any leaks.

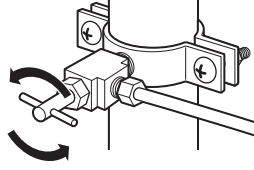

PLUG IN THE REFRIGERATOR

On models with an icemaker, before plugging in the refrigerator, make sure the icemaker power switch is set to the 0 (off) position.

See the grounding information attached to the power cord.

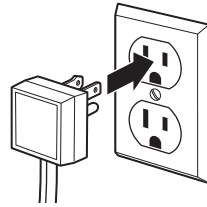

PUT THE REFRIGERATOR IN PLACE

Move the refrigerator to its final location.

LEVEL THE REFRIGERATOR

Adjustable legs at the front corners of the refrigerator should be set so the refrigerator is firmly positioned on the floor, and the front is raised just enough that the door closes easily when opened about halfway.

To adjust the leveling legs, turn the legs **clockwise to raise** the refrigerator, **counterclockwise to lower** it.

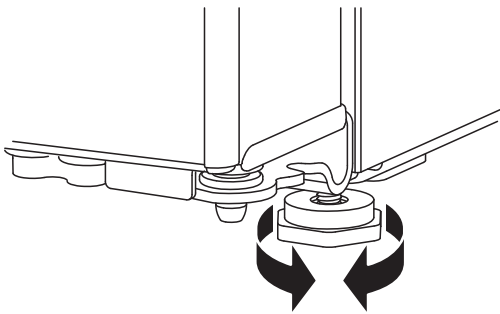

LEVEL THE REFRIGERATOR DOORS (on some models)

Remember a level refrigerator is necessary for getting the doors perfectly even. If you need help, review the previous section on leveling the refrigerator.

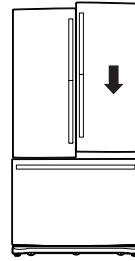

When the left door is lower than the right door.

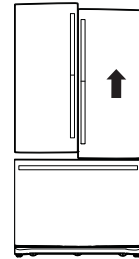

When the left door is higher than the right door.

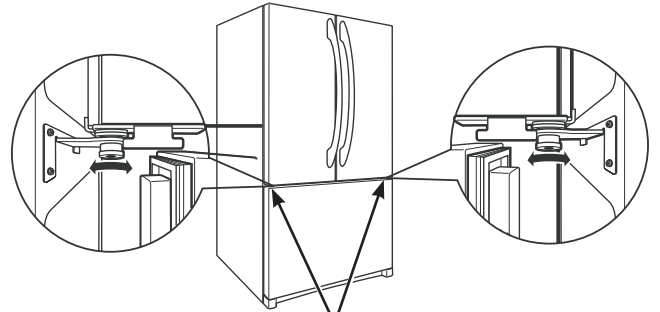

Adjustment point

If the doors remain uneven, turn the adjustable pin to raise the lowest door using a 1/4" allen wrench to turn the pin.

Installation Instructions

Refrigerator suggested assembly

Shelves shown in the location for best energy efficiency.

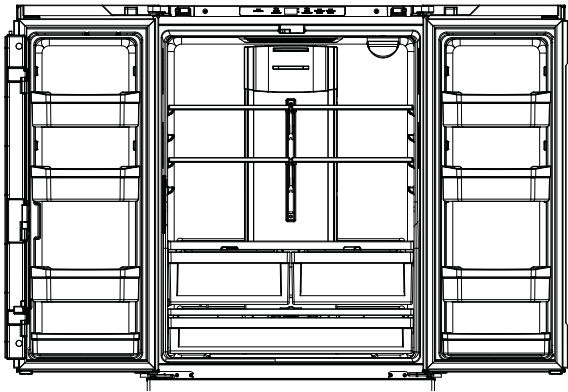

CWE19S 19 cuft. Models
French Door with Freezer Drawer

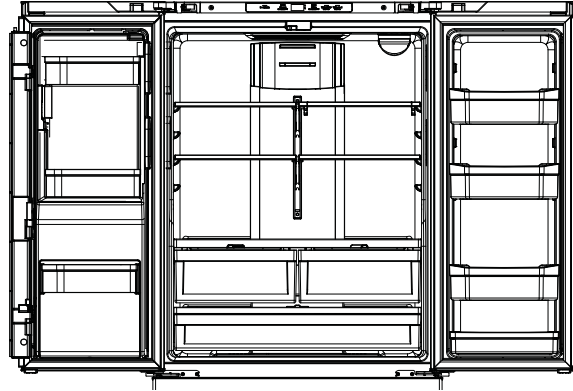

CFE26K 26 cuft. Models
French Door with Freezer Drawer

NOTE: Do not block air outlet by placing food items directly against it. Erratic temperatures may result.

Installation Instructions

INSTALLING THE WATER LINE

BEFORE YOU BEGIN

If the water supply to the refrigerator is from a Reverse Osmosis Water Filtration System (RO) AND the refrigerator also has a water filter, use the refrigerator's filter bypass plug. Using the refrigerator's water filtration cartridge in conjunction with an RO water filter can result in hollow ice cubes. Some models do not come equipped with the filter bypass plug. To obtain a free bypass plug, visit cafeappliances.com/service. In Canada, visit cafeappliances.ca/service.

This water line installation is not warranted by the refrigerator or icemaker manufacturer. Follow these instructions carefully to minimize the risk of expensive water damage.

Water hammer (water banging in the pipes) in house plumbing can cause damage to refrigerator parts and lead to water leakage or flooding. Call a qualified plumber to correct water hammer before installing the water supply line to the refrigerator.

To prevent burns and product damage, do not hook up the water line to the hot water line.

Do not install the icemaker tubing in areas where temperatures fall below freezing.

When using any electrical device (such as a power drill) during installation, be sure the device is double insulated or grounded in a manner to prevent the hazard of electric shock, or is battery powered.

All installations must be in accordance with local plumbing code requirements.

WHAT YOU WILL NEED

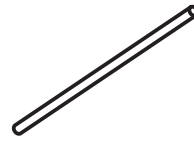

- Copper or Universal Water Line Refrigerator Tubing Kit, 1/4" outer diameter to connect the refrigerator to the water supply. If using copper, be sure both ends of the tubing are cut square.

To determine how much tubing you need: measure the distance from the water valve on the back of the refrigerator to the water supply pipe. Be sure there is sufficient extra tubing to allow the refrigerator to move out from the wall after installation.

Universal Water Line Refrigerator Tubing Kits are available in the following lengths:

6' (1.8 m) – WX08X10006

15' (4.6 m) – WX08X10015

25' (7.6 m) – WX08X10025

▲ WARNING

Connect to potable water supply only.

A cold water supply is required for automatic icemaker operation. The water pressure must be between 40 and 120 psi (275-827 kilopascals)

Installation Instructions

INSTALLING THE WATER LINE (Cont.)

WHAT YOU WILL NEED (Cont.)

NOTE: The only Crosley approved plastic tubing is that supplied in Universal Water Line Refrigerator Tubing Kits. Do not use any other plastic water supply line because the line is under pressure at all times. Certain types of plastic will crack or rupture with age and cause water damage to your home.

- A water supply kit (containing tubing, shutoff valve and fittings listed below) is available at extra cost from your dealer or from cafeappliances.com/parts. In Canada, visit cafeappliances.ca/parts.
- A cold water supply. The water pressure must be between 20 and 120 p.s.i. (138-827 kPa).

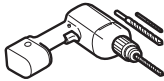

- Power drill.
- 1/2" or adjustable wrench.
- Straight and Phillips blade screwdriver.

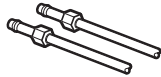

- Two 1/4" outer diameter compression nuts and 2 ferrules (sleeves)—to connect the copper tubing to the shutoff valve and the refrigerator water valve. OR

- If you are using a Universal Water Line Refrigerator Tubing Kit, the necessary fittings are preassembled to the tubing.

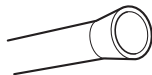

- If your existing copper water line has a flared fitting at the end, you will need an adapter (available at plumbing supply stores) to connect the water line to the refrigerator OR you can cut off the flared fitting with a tube cutter and then use a compression fitting. Do not cut formed end from Universal Water Line Refrigerator tubing.

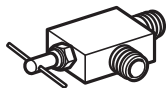

- Shutoff valve to connect to the cold water line. The shutoff valve should have a water inlet with a minimum inside diameter of 5/32" at the point of connection to the COLD WATER LINE. Saddle-type shutoff valves are included in many water supply kits. Before purchasing, make sure a saddle-type valve complies with your local plumbing codes.

Install the shutoff valve on the nearest frequently used drinking water line.

1 SHUT OFF THE MAIN WATER SUPPLY

Turn on the nearest faucet long enough to clear the line of water.

2 CHOOSE THE VALVE LOCATION

Choose a location for the valve that is easily accessible. It is best to connect into the side of a vertical water pipe. When it is necessary to connect into a horizontal water pipe, make the connection to the top or side, rather than at the bottom, to avoid drawing off any sediment from the water pipe.

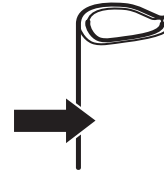

3 DRILL THE HOLE FOR THE VALVE

Drill a 1/4" hole in the water pipe (even if using a self-piercing valve), using a sharp bit. Remove any burrs resulting from drilling the hole in the pipe.

Take care not to allow water to drain into the drill.

Failure to drill a 1/4" hole may result in reduced ice production or smaller cubes.

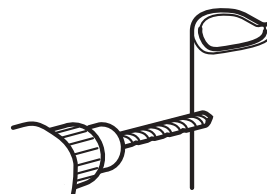

Installation Instructions

INSTALLING THE WATER LINE (Cont.)

4 FASTEN THE SHUTOFF VALVE

Fasten the shutoff valve to the cold water pipe with the pipe clamp.

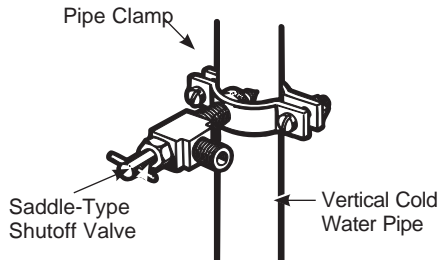

NOTE: Commonwealth of Massachusetts Plumbing Codes 248CMR shall be adhered to. Saddle valves are illegal and use is not permitted in Massachusetts. Consult with your licensed plumber.

5 TIGHTEN THE PIPE CLAMP

Tighten the clamp screws until the sealing washer begins to swell.

NOTE: Do not over tighten or you may crush the tubing.

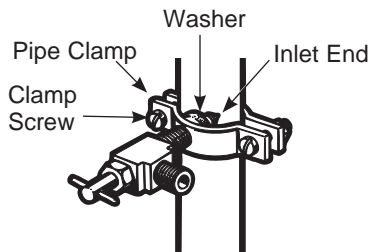

6 ROUTE THE TUBING

Route the tubing between the cold water line and the refrigerator.

Route the tubing through a hole drilled in the wall or floor (behind the refrigerator or adjacent base cabinet) as close to the wall as possible.

7 FASTEN THE SHUTOFF VALVE

Place the compression nut and ferrule (sleeve) for copper tubing onto the end of the tubing and connect it to the shutoff valve.

Make sure the tubing is fully inserted into the valve. Tighten the compression nut securely.

For plastic tubing from a Universal Water Line Refrigerator Tubing Kit, insert the molded end of the tubing into the shutoff valve and tighten compression nut until it is hand tight, then tighten one additional turn with a wrench. Over tightening may cause leaks.

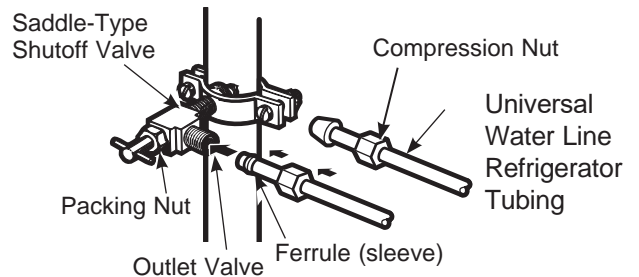

NOTE: Commonwealth of Massachusetts Plumbing Codes 248CMR shall be adhered to. Saddle valves are illegal and use is not permitted in Massachusetts. Consult with your licensed plumber.

8 FLUSH OUT THE TUBING

Turn the main water supply on and flush out the tubing until the water is clear.

Shut the water off at the water valve after about one quart (1 liter), or 2 minutes, of water has been flushed through the tubing.



Normal Operating Conditions.

Newer refrigerators sound different from older refrigerators. Modern refrigerators have more features and use newer technology.

Do you hear what I hear? These conditions are normal.

HUMMM...



WHOOSH...

- The new high efficiency compressor may run faster and longer than your old refrigerator and you may hear a high-pitched hum or pulsating sound while it is operating.
- You may hear a whooshing sound when the doors close. This is due to pressure equalizing within the refrigerator.

WHIR!



- You may hear the fans spinning at high speeds. This happens when the refrigerator is first plugged in, when the doors are opened frequently or when a large amount of food is added to the refrigerator or freezer compartments. The fans are helping to maintain the correct temperatures.
- The fans change speeds in order to provide optimal cooling and energy savings.

CLICKS, POPS, CRACKS and SNAPS

- You may hear cracking or popping sounds when the refrigerator is first plugged in. This happens as the refrigerator cools to the correct temperature.
- Expansion and contraction of cooling coils during and after defrost can cause a cracking or popping sound.
- On models with an icemaker, after an ice making cycle, you may hear the ice cubes dropping into the ice bucket.
- On models with a dispenser, during water dispense, you may hear the water lines move at initial dispense and after dispenser button is released.

WATER SOUNDS



- The flow of refrigerant through the cooling coils may make a gurgling noise like boiling water.
- Water dropping on the defrost heater can cause a sizzling, popping or buzzing sound during the defrost cycle.
- A water dripping noise may occur during the defrost cycle as ice melts from the evaporator and flows into the drain pan.
- Closing the door may cause a gurgling sound due to pressure equalization.

Troubleshooting Tips... Before you call for service

Save time and money! Review the charts on the following pages first and you may not need to call for service.

Problem	Possible Causes	What to Do
Refrigerator does not operate	Refrigerator in defrost cycle.	Wait about 30 minutes for defrost cycle to end.
	Either or both controls set to OFF.	Set the controls to a lower temperature setting.
	Refrigerator is unplugged.	Push the plug completely into the outlet.
	The fuse is blown/circuit breaker is tripped.	Replace fuse or reset the breaker.
	Refrigerator is in showroom mode.	Unplug the refrigerator and plug it back in.
Vibration or rattling (slight vibration is normal)	Leveling legs need adjusting.	See Level the refrigerator.

Troubleshooting Tips... Before you call for service

Save time and money! Review the charts on the following pages first and you may not need to call for service.

Problem	Possible Causes	What to Do
Motor operates for long periods or cycles on and off frequently. (Modern refrigerators with more storage space and a larger freezer require more operating time. They start and stop often to maintain even temperatures.)	Normal when refrigerator is first plugged in.	Wait 24 hours for the refrigerator to completely cool down.
	Often occurs when large amounts of food are placed in refrigerator.	This is normal.
	Door left open.	Check to see if package is holding door open.
	Hot weather or frequent door openings.	This is normal.
	Temperature controls set at the coldest setting.	See Controls section
Refrigerator or freezer compartment too warm	Temperature control not set cold enough.	See Controls section
	Warm weather or frequent door openings.	Set the temperature control one step colder. See Controls section
	Door left open.	Check to see if package is holding door open.
Frost or ice crystals on frozen food (frost within package is normal)	Door left open.	Check to see if package is holding door open.
	Too frequent or too long door openings.	This is normal.
Divider between refrigerator and freezer compartments feels warm	Automatic energy saver system circulates warm liquid around front edge of freezer compartment.	This helps prevent condensation on the outside.
Automatic icemaker does not work	Icemaker power switch is in the OFF position.	Set the power switch to the ON position.
	Water supply turned off or not connected.	See Installing the Water Line section
	Freezer compartment too warm.	Wait 24 hours for the refrigerator to completely cool down.
	Piled up cubes in the storage bin cause the icemaker to shut off.	Level cubes by hand.
	Ice cubes stuck in icemaker.	Turn off the icemaker, remove cubes, and turn the icemaker back on.
	Filter is not properly installed Filter water leak	Replace filter or make sure the water filter is properly installed (see water filter section).
Freezer cooling, refrigerator not cooling	Normal, when refrigerator first plugged in or after extended power outage	Wait 24 hours for temperature in both compartments to reach selected temperatures.
Ice dispenser opens after closing freezer drawer	Normal	The ice dispenser door may open after closing freezer door to allow access.
Ice cubes have odor/taste	Ice storage bin needs cleaning.	Empty and wash bin. Discard old cubes.
	Food transmitting odor/taste to ice cubes.	Wrap foods well.
	Interior of refrigerator needs cleaning.	See Care and Cleaning section.
Small or hollow cubes	Water filter clogged.	Replace filter cartridge with new cartridge or with plug.
Slow ice cube freezing	Door left open.	Check to see if package is holding door open.
	Temperature control not set cold enough.	See Controls section
Frequent 'buzzing sound'	Icemaker switch is in the on position, but the water supply to the refrigerator has not been connected.	Set the switch to the off position. Keeping it in the on position will damage the water valve.
Water has poor taste/odor	Water dispenser has not been used for a long time.	Dispense water until all water in system is replenished.

Troubleshooting Tips... Before you call for service

Save time and money! Review the charts on the following pages first and you may not need to call for service.

Problem	Possible Causes	What to Do
Water in first glass is warm	Normal when refrigerator is first installed.	Wait 24 hours for the refrigerator to completely cool down.
	Water dispenser has not been used for a long time.	Dispense water until all water in system is replenished.
	Water system has been drained.	Allow several hours for replenished supply to chill.
Water dispenser does not work	Water supply line turned off or not connected.	See Installing the water line section
	Water filter clogged.	Replace filter cartridge or remove filter and install plug.
	Air may be trapped in the water system.	Press the dispenser arm for at least two minutes.
	Dispenser is LOCKED.	Press and hold the LOCK pad for 3 seconds.
Water spurting from dispenser	Newly-installed filter cartridge.	Run water from the dispenser for 3 minutes (about one and a half gallons).
Water is not dispensed but icemaker is working	Water in reservoir is frozen.	Call for service.
	Refrigerator control setting is too cold.	Set to a warmer setting.
No water or ice cube production	Supply line or shutoff valve is clogged.	Call a plumber.
	Water filter clogged.	Replace filter cartridge or remove filter and install plug.
	Filter is not properly installed Filter water leak	Replace filter or make sure the water filter is properly installed (see water filter section).
Refrigerator has odor	Foods transmitting odor to refrigerator.	Foods with strong odors should be tightly wrapped. Keep an open box of baking soda in the refrigerator; replace every three months.
	Interior needs cleaning.	See Care and Cleaning section
Moisture forms on outside of refrigerator	Not unusual during periods of high humidity.	Wipe surface dry.
Moisture collects inside (in humid weather, air carries moisture into refrigerator when doors are opened)	Too frequent or too long door openings.	This is normal.
	Due to the higher humidity in the refrigerator, you may on occasion experience fog or small amounts of moisture in the refrigerator compartment.	This is normal and may come and go as different food loads and environmental conditions change. Wipe dry with a paper towel if desired.
Interior light does not work	No power at outlet.	Replace fuse or reset the breaker.
	LED lights are out	Call Service - see Replacing the Lights
Hot air from bottom of refrigerator	Normal air flow cooling motor. In the refrigeration process, it is normal that heat be expelled in the area under the refrigerator. Some floor coverings are sensitive and will discolor at these normal and safe temperatures.	This is normal.
Refrigerator never shuts off but the temperatures are OK	Adaptive defrost keeps compressor running during door openings.	This is normal. The refrigerator will cycle off after the door remains closed for 2 hours.
Refrigerator is beeping	Door is open.	Close door.
Door not closing properly	Door gasket on hinge side sticking or folding over.	Apply paraffin wax to the face of the gasket.
Actual temperature not equal to Set temperature	Unit just plugged in.	Allow 24 hours for system to stabilize.
	Door open for too long.	Allow 24 hours for system to stabilize.
	Warm food added to refrigerator.	Allow 24 hours for system to stabilize.
	Defrost cycle is in process.	Allow 24 hours for system to stabilize.
Door/drawer does not close by itself	Leveling legs need adjusting.	See Level the refrigerator

Troubleshooting Tips... Before you call for service

Problem	Possible Causes	What to Do
Freezer drawer pops open when refrigerator door is closed	This is normal if, after popping open, the freezer drawer closed on its own.	This indicates that there is a good seal on the freezer drawer. If the freezer drawer does not automatically close after popping open, then see the Problem: Door/ drawer does not close by itself, above.
Food freezing in the refrigerator	Food too close to the air vent at the back of the refrigerator.	Move the food away from the air vent.
	Refrigerator control is set too cold.	Move the refrigerator control to a warmer temperature setting one increment at a time.
Water is leaking from dispenser	Glass not being held under the dispenser long enough after button is released.	Hold the glass underneath the dispenser for 2–3 seconds after releasing the dispenser button. Water may continue to dispense after the button is released
	Air may be present in the water line system, causing water to drip after being dispensed.	Dispense water for at least 2 minutes to remove air from system.
My display is showing tc	Turbo Cool function is activated.	See Controls section
Water filter indicator light changed color	This is normal.	See Water Filter Cartridge - XWFE section
Water filter indicator light remains red even after replacing the water filter	Improperly installed filter Leak is detected Using expired filter	Verify you have the XWFE filter and not XWF. Verify no scratches or damage to filter label. Replace filter if label shows damage. See Water Filter Cartridge - XWFE section
	Water filter indicator must be reset. (on some models)	Press and hold the WATER FILTER pad for 3 seconds. See Water Filter Cartridge section.
Water filter indicator light is not lit	This is normal. The filter cartridge should be replaced when the replacement indicator light turns red.	See Water Filter Cartridge - XWFE section
Handle is loose / handle has a gap	Handle needs adjusting.	See Attach the Refrigerator Handle and Attach the Freezer Handle sections
Refrigerator doors are not even	Doors need realigning.	See Level the Refrigerator Doors section.
Baskets stick or jam when opening or closing	Baskets are too full.	To open: remove some of the products from the basket when opened as far as possible. Readjust the products left in the basket and try to open the basket again. To close: readjust products in the basket or remove any product that is above the rim of the basket and close the basket.
Filter Status Indicator LED turns red	Filter reaching expired state or expired	Press the Filter Status pad to show remaining filter life. If the display shows 0%, the filter needs to be replaced. When the unit has detected a new filter (a filter has been replaced) the Filter Status LED will flash 3 times and then remain off to indicate the filter was successfully replaced.
LEAK or scrolling "LEAK" on the display Water is disabled Filter Status indicator LED flashing red Buzzer sound	Filter leak detected	Replace filter. Wipe off the filter/surrounding area if there is any water from filter replacement.
"Err" on the display Water is disabled Filter Status indicator LED flashing red Buzzer sound	Filter is not detected No communication with filter	Verify you have the XWFE filter and not the XWF. Verify there are no scratches or filter label damage. Replace filter if filter label shows damage.
Refrigerator beeps when pressing dispenser paddle	Filter is not properly installed Filter water leak	Replace filter or make sure the water filter is properly installed (see water filter section).

Café Refrigerator Limited Warranty

LIMITED WARRANTY

cafeappliances.com

All warranty service is provided by our Factory Service Centers, or an authorized service technician. To schedule service online, visit us at **cafeappliances.com/service**. Please have your serial number and your model number available when scheduling service. In Canada, visit **cafeappliances.ca/service**.

Servicing your refrigerator may require the use of the onboard data port for diagnostics. This gives a Café Factory Service technician the ability to quickly diagnose any issues with your appliance and helps Café improve its products by providing Café with information on your appliance. If you do not want your appliance data to be sent to Café, please advise your technician **NOT** to submit the data to Café at the time of service.

For the Period of:	Café Will Replace
One Year From the date of the original purchase	Any part of the refrigerator which fails due to a defect in materials or workmanship. During the limited one-year warranty , Café will also provide, free of charge , all labor and related service to replace the defective part.
Thirty Days (Water filter, if included) From the original purchase date of the refrigerator	Any part of the water filter cartridge which fails due to a defect in materials or workmanship. During this limited thirty-day warranty , Café will also provide, free of charge , a replacement water filter cartridge.
Five Years From the date of the purchase	Any part of the sealed refrigerating system (the compressor, condenser, evaporator and all connecting tubing) which fails due to a defect in materials or workmanship. During this limited five-year sealed refrigerating system warranty , Café will also provide, free of charge , all labor and related service to replace the defective part in the sealed refrigerating system.

What Café Will Not Cover:

- Service trips to your home to teach you how to use the product.
- Improper installation, delivery or maintenance.
- Failure of the product if it is abused, misused, or used for other than the intended purpose or used commercially.
- Loss of food due to spoilage.
- Replacement of house fuses or resetting of circuit breakers.
- Damage to finish, such as surface rust, tarnish, or small blemishes not reported within 48 hours of delivery.
- Replacement of the water filter cartridge, if included, due to water pressure that is outside the specified operating range or due to excessive sediment in the water supply.
- Replacement of the light bulbs, if included, or water filter cartridge, if included, other than as noted above.
- Damage to the product caused by accident, fire, floods or acts of God.
- Incidental or consequential damage caused by possible defects with this appliance.
- Product not accessible to provide required service.
- Damage caused by a non-GE Appliances Brand water filter.

EXCLUSION OF IMPLIED WARRANTIES

Your sole and exclusive remedy is product repair as provided in this Limited Warranty. Any implied warranties, including the implied warranties of merchantability or fitness for a particular purpose, are limited to one year or the shortest period allowed by law.

For US Customers: This limited warranty is extended to the original purchaser and any succeeding owner for products purchased for home use within the USA. If the product is located in an area where service by a Café Authorized Servicer is not available, you may be responsible for a trip charge or you may be required to bring the product to an Authorized Café Service location for service. In Alaska, the limited warranty excludes the cost of shipping or service calls to your home.

Some states do not allow the exclusion or limitation of incidental or consequential damages. This limited warranty gives you specific legal rights, and you may also have other rights which vary from state to state. To know what your legal rights are, consult your local or state consumer affairs office or your state's Attorney General.

Warrantor: GE Appliances, a Haier company
Louisville, KY 40225

For Customers in Canada: This limited warranty is extended to the original purchaser and any succeeding owner for products purchased in Canada for home use within Canada. In-home warrant service will be provided in areas where it is available and deemed reasonable by Mabe to provide.

Warrantor Canada: MC Commercial, Inc., Burlington, Ontario, L7R 5B6

Staple your receipt here. Proof of the original purchase date is needed to obtain service under the warranty.

Water Filter Cartridge XWFE Limited Warranty

Contact us at cafeappliances.com/parts..

For the period of	GE Appliances will replace
Thirty Days From the date of the original purchase	Any part of the water filter cartridge which fails due to a defect in materials or workmanship during this limited thirty-day warranty.*

What GE Appliances will not cover:

- Service trips to your home to teach you how to use the product.
- Improper installation.
- Failure of the product if it is abused, misused, used for other than the intended purpose or used commercially.
- Replacement of house fuses or resetting of circuit breakers.
- Damage to the product caused by accident, fire, floods, or acts of God.
- Incidental or consequential damage caused by possible defects with this appliance.

EXCLUSION OF IMPLIED WARRANTIES
Your sole and exclusive remedy is part exchange as provided in this Limited Warranty. Any implied warranties, including the implied warranties of merchantability or fitness for a particular purpose, are limited to six months or the shortest period allowed by law.

This warranty is extended to the original purchaser and any succeeding owner for products purchased for home use within the USA. In Alaska, the warranty excludes the cost of shipping or service calls to your home.

Some states do not allow the exclusion or limitation of incidental or consequential damages. This warranty gives you specific legal rights, and you may also have other rights which vary from state to state. To know what your legal rights are, consult your local or state consumer affairs office or your state's Attorney General.

For Purchases Made In Iowa: This form must be signed and dated by the buyer and seller prior to the consummation of this sale.

This form should be retained on file by the seller for a minimum of two years.

Staple your receipt here. Proof of the original purchase date is needed to obtain service under the warranty.

Buyer:

Name _____

Address _____

City _____ State _____ Zip _____

Signature _____ Date _____

Seller:

Name _____

Address _____

City _____ State _____ Zip _____

Signature _____ Date _____

*If your GE Appliances part fails because of a manufacturing defect within thirty days from the date of original purchase for use, we will give you a new or, at our option, a rebuilt part without charge. Return the defective part to the parts supplier from whom it was purchased together with a copy of the "proof of purchase" for the part. If the part is defective and shows no signs of abuse, it will be exchanged. The warranty does not cover the failure of parts which are damaged while in your possession, are abused, or have been installed improperly. It does not cover the cost of returning the part to the supplier from whom it was purchased nor does it cover the cost of labor to remove or install it to diagnose the fault. It does not cover parts used in products in commercial use except in the case of air conditioning equipment. In no event shall GE Appliances be liable for consequential damages.

Warrantor: GE Appliances, a Haier company
Louisville, KY 40225

Performance Data Sheet

Model: XWFE

- System certified by IAPMO R&T against NSF/ANSI Standards 42, 53, 401, and P473 for the reduction of claims specified on the performance data sheet and at iapmort.org.
- Actual performance may vary with local water conditions.

Substance Tested for Reduction	Influent challenge concentration (mg/L)	Maximum permissible product water concentration (mg/L)	Avg % Reduction
Chlorine Taste and Odor	2.0 mg/L +/- 10%	N/A	> 99
Chloramine Taste and Odor	3.0 mg/L +/- 10%	0.5	> 99
Particulate, Class I	At least 10,000/mL	N/A	91.4
Cysts	50,000/L	N/A	> 99.99
Lead	0.15	0.01	98.85
Mercury	0.006	0.002	96.95
Asbestos	107 to 108 fibers/ L	N/A	> 99
Toxaphene	0.015 +/- 10%	0.003	86.95
VOC (Chloroform surrogate chemical)	0.300	0.015	> 99
Alachlor	0.050	0.001	> 98
Atrazine	0.100	0.003	> 97
Benzene	0.081	0.001	> 99
Carbofuran	0.190	0.001	> 99
carbon tetrachloride	0.078	0.0018	98
chlorobenzene	0.077	0.001	> 99
chloropicrin	0.015	0.0002	99
2,4-D	0.110	0.0017	98
dibromochloropropane (DBCP)	0.052	0.00002	> 99
o-Dichlorobenzene	0.08	0.001	> 99
p-Dichlorobenzene	0.040	0.001	> 98
1,2-dichloroethane	0.088	0.0048	95
1,1-dichloroethylene	0.083	0.001	> 99
cis-1,2-dichloroethylene	0.170	0.0005	> 99
trans-1,2-dichloroethylene	0.086	0.001	> 99
1,2-dichloropropane	0.080	0.001	> 99
cis-1,3-dichloropropylene	0.079	0.001	> 99
dinoseb	0.170	0.0002	99
Endrin	0.053	0.00059	99
Ethylbenzene	0.088	0.001	> 99
ethylene dibromide (EDB)	0.044	0.00002	> 99
bromochloroacetonitrile	0.022	0.0005	98
dibromoacetonitrile	0.024	0.0006	98
dichloroacetonitrile	0.0096	0.0002	98
trichloroacetonitrile	0.015	0.0003	98
1,1-dichloro-2-propanone	0.0072	0.0001	99
1,1,1-trichloro-2-propanone	0.0082	0.0003	96
heptachlor (H-34, Heptox)	0.025	0.00001	> 99
heptachlor epoxide	0.0107	0.0002	98
hexachlorobutadiene	0.044	0.001	> 98
hexachlorocyclopentadiene	0.060	0.000002	> 99
Lindane	0.055	0.00001	> 99
methoxychlor	0.050	0.0001	> 99
pentachlorophenol	0.096	0.001	> 99
simazine	0.120	0.004	> 97
Styrene	0.150	0.0005	> 99
1,1,2,2-tetrachloroethane	0.081	0.001	> 99
Tetrachloroethylene	0.081	0.001	> 99
Toluene	0.078	0.001	> 99
2,4,5-TP (silvex)	0.270	0.0016	99
tribromoacetic acid	0.042	0.001	> 98
1,2,4-Trichlorobenzene	0.160	0.0005	> 99
1,1,1-trichloroethane	0.084	0.0046	95
1,1,2-trichloroethane	0.150	0.0005	> 99
trichloroethylene	0.180	0.0010	> 99
bromoform	0.300	0.015	95
bromodichloromethane	0.300	0.015	95
chlorodibromomethane	0.300	0.015	95
xylenes	0.070	0.001	> 99
Meprobamate	400 +/- 20%	60	> 99
Atenolol	200 +/- 20%	30	> 99
Carbamazepine	1400 +/- 20%	200	> 99
DEET	1400 +/- 20%	200	> 99
Metolachlor	1400 +/- 20%	200	> 99
Trimethoprim	140 +/- 20%	20	> 99
Linuron	140 +/- 20%	20	> 99
TCEP	5000 +/- 20%	700	> 99
T CPP	5000 +/- 20%	700	> 99
Phenytoin	200 +/- 20%	30	> 99
Ibuprofen	400 +/- 20%	60	> 99
Naproxen	140 +/- 20%	20	> 99
Estrone	140 +/- 20%	20	> 99
Bisphenol A	2000 +/- 20%	300	> 99
Nonyl phenol	1400 +/- 20%	200	> 99
PFOA/PFOS	1.5 mg/L +/- 10%	0.07	99.25

Application Guidelines/Water Supply Parameters

Service Flow	0.5 gpm (1.89 lpm)
Water Supply	Potable Water
Water Pressure	25-120 psi (172-827 kPa)
Water Temperature	33°F-100°F (0.6°C-38°C)
Capacity	170 gallons (643.5 liters)

It is essential that the manufacturer's recommended installation, maintenance and filter replacement requirements be carried out for the product to perform as advertised. See Installation Manual for Warranty information.

NOTE: While the testing was performed under standard laboratory conditions, actual performance may vary. Replacement Cartridge: XWFE. For estimated costs of replacement elements please visit our website at cafeappliances.com.

⚠ WARNING To reduce the risk associated with ingestion of contaminants:

- Do not use with water that is microbiologically unsafe or of unknown quality without adequate disinfection before and after the system. Systems certified for cyst reduction may be used on disinfected water that may contain filterable cysts.

NOTICE

To reduce the risk of water leakage or flooding, and to ensure optimal filter performance:

- Read and follow use instructions before installation and use of this system.
- Installation and use **MUST** comply with all state and local plumbing codes.
- Do not install if water pressure exceeds 120 psi (827 kPa). If your water pressure exceeds 80 psi, you **must** install a pressure-limiting valve. Contact a plumbing professional if you are uncertain how to check your water pressure.
- Do not install where water hammer conditions may occur. If water hammer conditions exist you **must** install a water hammer arrester. Contact a plumbing professional if you are uncertain how to check for this condition.
- Do not install on hot water supply lines. The maximum operating water temperature of this filter system is 100° F (38° C).
- **Protect filter from freezing.** Drain filter when temperatures drop below 33°F (0.6°C).
- Change the disposable filter cartridge every six months or sooner if you observe a noticeable reduction in water flow rate.
- Failure to replace the disposable filter cartridge at recommended intervals may lead to reduced filter performance and cracks in the filter housing, causing water leakage or flooding.
- This System has been tested according to NSF/ANSI 42, 53, 401 and P473 for the reduction of the substances listed below. The concentration of the indicated substances in water entering the system was reduced to a concentration less than or equal to the permissible limit for water leaving the system, as specified in NSF/ANSI 42, 53, 401 and P473.



XWFE System is certified by IAPMO R&T against NSF/ANSI Standards 42, 53, 401, and P473 for the reduction of claims specified on the performance data sheet and at iapmort.org.

Appliance Communication (on some models)

GE WiFi Connect Optional*

Your refrigerator is **GE WiFi Connect** compatible using the **GE ConnectPlus** module. To connect this appliance to the internet you will need to attach the module to your appliance through the communication port in the appliance. The **GE ConnectPlus** will allow your appliance to communicate with your smart phone for remote appliance monitoring, control and notifications. Please visit GEAppliances.com/connect to learn more about connected appliance features, to learn what connected appliance App's will work with your Smart Phone and to learn where you can purchase a **GE ConnectPlus**.**

Plug the ConnectPlus module into the RJ45 port located on the backside of the top refrigerator control cover. No need to remove the cover.

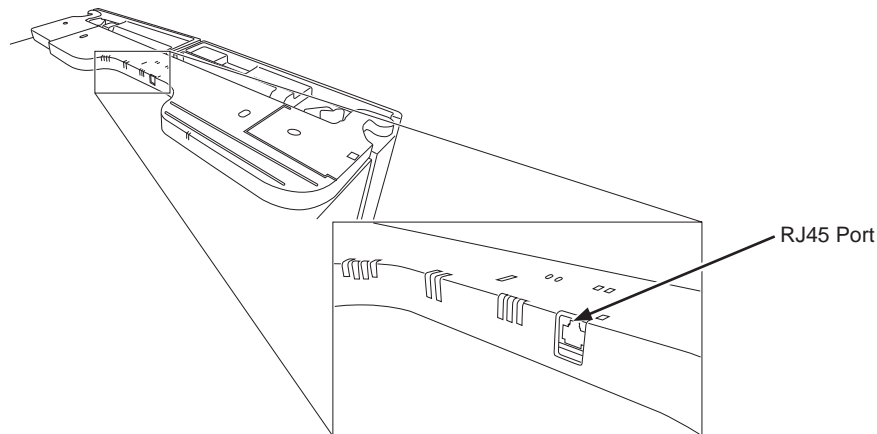

WiFi Connectivity: For assistance with the appliance or the **ConnectPlus** network connectivity (for models that are WiFi enabled or WiFi optional), please call **1-800-220-6899**.

REGULATORY INFORMATION

FCC/IC Compliance Statement:

This device complies with Part 15 of the FCC Rules. This device contains license-exempt transmitter(s)/receiver(s) that comply with Innovation, Science and Economic Development, Canada's license-exempt RSS(s). Operation is subject to the following two conditions:

1. This device may not cause harmful interference.
2. This device must accept any interference received, including interference that may cause undesired operation.

This equipment has been tested and found to comply with the limits for a Class B digital device, pursuant to Part 15 of the FCC Rules. These limits are designed to provide reasonable protection against harmful interference in a residential installation. This equipment generates, uses and can radiate radio frequency energy and, if not installed and used in accordance with the instructions, may cause harmful interference to radio communications. However, there is no guarantee that interference will not occur in a particular installation. If this equipment does cause harmful interference to radio or television reception, which can be determined by turning the equipment off and on, the user is encouraged to try to correct the interference by one or more of the following measures:

- Reorient or relocate the receiving antenna.
- Increase the separation between the equipment and receiver.
- Connect the equipment into an outlet on a circuit different from that to which the receiver is connected.
- Consult the dealer or an experienced radio/television technician for help.

Labelling: Changes or modifications to this unit not expressly approved by the manufacturer could void the user's authority to operate the equipment.

ConnectPlus module only (or similar communication module)

RF Exposure - This device is only authorized for use in a mobile application. At least 20 cm of separation distance between the **ConnectPlus** device and the user's body must be maintained at all times.

*Select Models Only ** For US, US Territories and Canada Only.

Notes

Consumer Support

Café Website

Have a question or need assistance with your appliance? Try the Café website 24 hours a day, any day of the year! You can also shop for more great Café products and take advantage of all our on-line support services designed for your convenience. In the US: cafeappliances.com

Register Your Appliance

Register your new appliance on-line at your convenience! Timely product registration will allow for enhanced communication and prompt service under the terms of your warranty, should the need arise. You may also mail in the pre-printed registration card included in the packing material. In the US: cafeappliances.com/register

Schedule Service

Expert Café repair service is only one step away from your door. Get on-line and schedule your service at your convenience any day of the year. In the US: cafeappliances.com/service

Extended Warranties

Purchase a Café extended warranty and learn about special discounts that are available while your warranty is still in effect. You can purchase it on-line anytime. Café Service will still be there after your warranty expires. In the US: cafeappliances.com/extended-warranty

Remote Connectivity

For assistance with wireless network connectivity (for models with remote enable), visit our website at cafeappliances.com/connect

Parts and Accessories

Individuals qualified to service their own appliances can have parts or accessories sent directly to their homes (VISA, MasterCard and Discover cards are accepted). Order on-line today 24 hours every day. In the US: cafeappliances.com/parts

Instructions contained in this manual cover procedures to be performed by any user. Other servicing generally should be referred to qualified service personnel. Caution must be exercised, since improper servicing may cause unsafe operation.

Contact Us

If you are not satisfied with the service you receive from Café, contact us on our website with all the details including your phone number, or write to:

In the US: General Manager, Customer Relations | Café Appliances, Appliance Park | Louisville, KY 40225
cafeappliances.com/contact