



DISTINCT BY DESIGN™

Owner's Manual

36" and 48" Professional Rangetops

Models: CGU366, CGU486

Contents

Safety Information	3	Troubleshooting Tips	14
Using the Rangetop		Limited Warranty	15
Features	6	Consumer Support	16
Surface Burners	7		
Top-of-the-Range Cookware	9		
Wok Cooking	9		
Griddle	10		
Care And Cleaning			
Control Panel and Knobs	11		
Rangetop Exterior	11		
Round, Inspiral, and Multi-Ring Burners	12		
Spark Igniter and Electrodes	13		
Burner Grates	13		
Grease Trough	13		
Griddle	13		

Write the model and serial numbers here:

Model # _____

Serial # _____

You'll find them on a label located below the control panel on the rating label.

English • Français • Español

THANK YOU FOR MAKING CAFÉ A PART OF YOUR HOME.

We take pride in the craftsmanship, innovation and design that goes into every Café product, and we think you will too. Among other things, registration of your appliance ensures that we can deliver important product information and warranty details when you need them.

Register your Café appliance now online. Helpful websites are available in the Consumer Support section of this Owner's Manual. You may also mail in the pre-printed registration card included in the packing material.



IMPORTANT SAFETY INFORMATION

READ ALL INSTRUCTIONS BEFORE USING THE APPLIANCE

▲ WARNING If the information in this manual is not followed exactly, a fire or explosion may result, causing property damage, personal injury or death.

- Do not store or use gasoline or other flammable vapors and liquids in the vicinity of this or any other appliance.
- **WHAT TO DO IF YOU SMELL GAS**
 - Do not try to light any appliance.
 - Do not touch any electrical switch; do not use any phone in your building.
 - Immediately call your gas supplier from a neighbor's phone. Follow the gas supplier's instructions.
 - If you cannot reach your gas supplier, call the fire department.
- Installation and service must be performed by a qualified installer, service agency or the gas supplier.

▲ WARNING Read all safety instructions before using the product. Failure to follow these instructions may result in fire, electrical shock, serious injury or death.

▲ WARNING GENERAL SAFETY INSTRUCTIONS

▲ WARNING NEVER use this appliance as a space heater to heat or warm the room. Doing so may result in carbon monoxide poisoning.

- Use this appliance for its intended purpose as described in this owner's manual.
- Have your rangetop installed and properly grounded by a qualified installer in accordance with the provided installation instructions.
- Any adjustment and service should be performed only by a qualified gas rangetop installer or service technician. Do not attempt to repair or replace any part of your rangetop unless it is specifically recommended in this manual.
- Your rangetop is shipped from the factory set for use with natural gas or propane (LP) gas. It can be converted for use with either. If required, these adjustments must be made by a qualified technician in accordance with the installation instructions and local codes. The agency performing this work assumes responsibility for the conversion.
- Have the installer show you the location of the rangetop gas shut-off valve and how to turn it off if necessary.
- Plug your rangetop into a 120-volt grounded outlet only. Do not remove the round grounding prong from the plug. If in doubt about the grounding of the home electrical system, it is your responsibility and obligation to have an ungrounded outlet replaced with a properly grounded, three prong outlet in accordance with the National Electrical Code. Do not use an extension cord with this appliance.
- Before performing any service, unplug the rangetop or disconnect the power supply at the household distribution panel by removing the fuse or switching off the circuit breaker.
- Be sure all packing materials are removed from the rangetop before operating to prevent ignition of these materials.
- Avoid scratching or impacting glass displays. Doing so may lead to glass breakage. Do not cook on a product with broken glass. Shock, fire, or cuts may occur.

READ AND SAVE THESE INSTRUCTIONS

IMPORTANT SAFETY INFORMATION

READ ALL INSTRUCTIONS BEFORE USING THE APPLIANCE

⚠ WARNING GENERAL SAFETY INSTRUCTIONS

- Do not leave children alone or unattended in an area where an appliance is in use. They should never be allowed to climb, sit or stand on any part of the appliance.
- **⚠ CAUTION** Do not store items of interest to children in cabinets above a rangetop - children climbing on the rangetop to reach items could be seriously injured.
- Never block the vents (air openings) of the rangetop. They provide the air inlets and outlets that are necessary for the rangetop to operate properly with correct combustion. Air openings are located at the rear of the rangetop.
- Use only dry pot holders—moist or damp pot holders on hot surfaces may result in burns from steam. Do not let pot holders touch surface burners or burner grate. Do not use a towel or other bulky cloth in place of pot holders.
- Do not touch the heating elements. These surfaces may be hot enough to burn even though they are dark in color. Other surfaces of the appliance may become hot enough to cause burns. Potentially hot surfaces include the burners, grates, high shelf surface.
- Do not heat unopened food containers. Pressure could build up and the container could burst, causing an injury.
- Cook food thoroughly to help protect against foodborne illness. Minimum safe food temperature recommendations can be found at IsItDoneYet.gov and fsis.usda.gov. Use a food thermometer to take food temperatures and check several locations.
- Do not allow anyone to climb, stand or hang on the rangetop. They could damage the appliance.
- Keep the ventilator hood and grease filters clean to maintain good venting and to avoid grease fires. Turn the ventilator OFF in case of a fire or when intentionally "flaming" liquor or other spirits on the rangetop. The blower if in operation, could spread the flames.

⚠ WARNING KEEP FLAMMABLE MATERIALS AWAY FROM THE RANGETOP

Failure to do so may result in fire or personal injury.

- Do not store or use flammable materials the rangetop, including paper, plastic, pot holders, linens, wall coverings, curtains, drapes and gasoline or other flammable vapors and liquids.
- Never wear loose-fitting or hanging garments while using the appliance. These garments may ignite if they contact hot surfaces causing severe burns.
- Do not let cooking grease or other flammable materials accumulate in or near the rangetop. Grease on the rangetop may ignite.

READ AND SAVE THESE INSTRUCTIONS

IMPORTANT SAFETY INFORMATION

READ ALL INSTRUCTIONS BEFORE USING THE APPLIANCE

▲WARNING IN THE EVENT OF A FIRE, TAKE THE FOLLOWING STEPS TO PREVENT INJURY AND FIRE SPREADING

- Do not use water on grease fires. Never pick up a flaming pan. Turn the controls off. Smother a flaming pan on a surface unit by covering the pan completely with a well-fitting lid, cookie sheet or flat tray. Use a multi-purpose dry chemical or foam-type fire extinguisher.

▲WARNING RANGETOP SAFETY INSTRUCTIONS

▲WARNING NEVER Operate the Top Surface Cooking Section of this Appliance Unattended.

- Failure to follow this warning statement could result in fire, explosion, or burn hazard that could cause property damage, personal injury, or death.
 - If a fire should occur, keep away from the appliance and immediately call your fire department.
- DO NOT ATTEMPT TO EXTINGUISH AN OIL/GREASE FIRE WITH WATER.**

- Never leave oil unattended while frying. If allowed to heat beyond its smoking point, oil may ignite resulting in fire that may spread to surrounding cabinets. Use a deep fat thermometer whenever possible to monitor oil temperature.
- To avoid oil spillover and fire, use the minimum amount of oil when using a shallow pan-frying and avoid cooking frozen foods with excessive amounts of ice.

- Use proper pan size and avoid pans that are unstable or easily tipped. Select cookware that is matched to the size of the burner. Burner flames should be adjusted so that they do not extend beyond the bottom of the pan. Excessive flame may be hazardous.
- Always use the LITE position when igniting the top burners and make sure the burners have ignited.
- When using glass/ceramic cookware, make sure it is suitable for cooktop service; others may break because of sudden change in temperature.
- To minimize the possibility of burns, ignition of flammable materials and spillage, the handle of a container should be turned toward the center of the range without extending over nearby burners.
- Do not use a wok with a round metal support ring. The ring may trap heat and block air to the burner resulting in a carbon monoxide hazard.
- Do not attempt to lift the cooktop. Doing so may damage the gas tubing to the surface burners resulting in a gas leak and risk of fire.
- Do not use aluminum foil to cover the grates or line any part of the cooktop. Doing so may result in carbon monoxide poisoning, overheating of the cooktop surfaces, or a potential fire hazard.

How to Remove Protective Shipping Film and Packaging Tape

Carefully grasp a corner of the protective shipping film with your fingers and slowly peel it from the appliance surface. Do not use any sharp items to remove the film. Remove all of the film before using the appliance for the first time.

To assure no damage is done to the finish of the product, the safest way to remove the adhesive from packaging tape on new appliances is an application of a household liquid dishwashing detergent. Apply with a soft cloth and allow to soak.

NOTE: The adhesive must be removed from all parts. It cannot be removed if it is baked on.

READ AND SAVE THESE INSTRUCTIONS

Using the Range

FEATURES

(Not all features are on all models. Appearance may vary.)

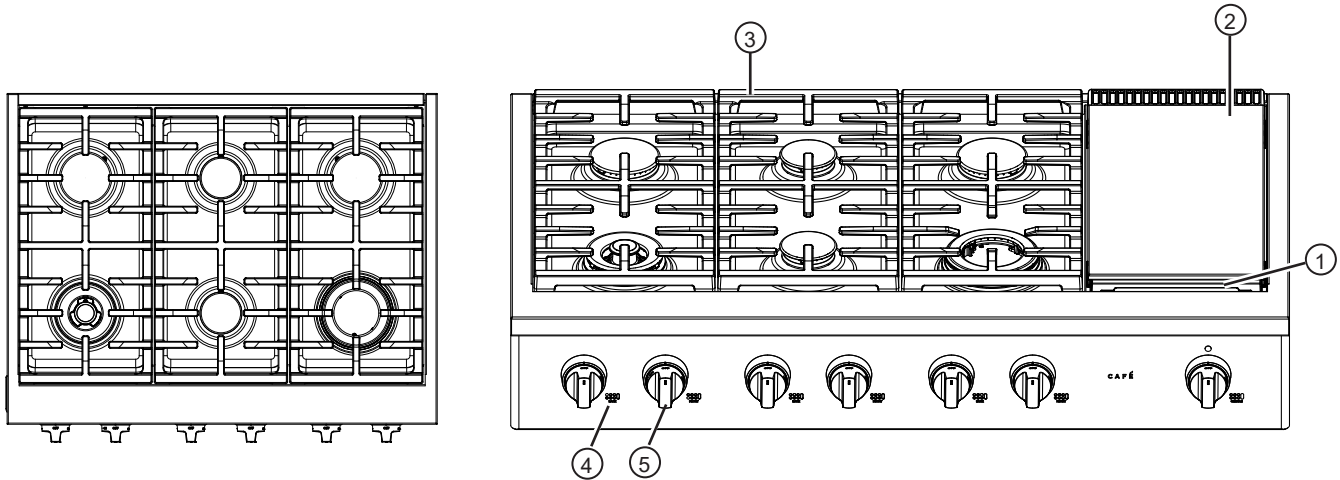

	Feature Index	Page
1	Griddle Grease Trough (on some models)	6
2	Griddle (on some models)	10
3	Cooktop Burner Grates	13
4	Burner Location Indicator	6
5	Burner Control Knob	7, 11

	Optional Accessories	Page
1	Griddle Cover	6

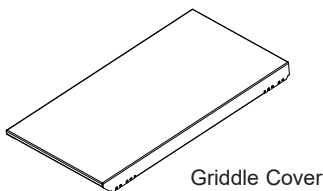

Using the Range

IN CASE OF A POWER FAILURE

In the event of a power failure, the surface burners may be lit with a match. Using extreme caution, hold a lit match near the ports beneath the surface burner cap, then slowly turn the knob to the LITE position. Once lit,

surface burners will continue to operate normally.

SURFACE BURNERS

Lighting a Surface Burner

⚠ WARNING Burners should be operated only when covered by cookware. Burner flames not covered by cookware present a risk of fire or clothing ignition. Never let flames extend beyond the sides of the cookware. Failure to comply may result in serious injury.

Make sure all burners are in their correct locations and fully assembled before attempting to operate any burner.

Select a burner and find its control knob. Push the knob in and turn it to the LITE position.

You will hear a clicking noise—the sound of the electric spark igniting the burner. When one burner is turned to LITE, all burners will spark. Sparking will continue as long as the knob remains at LITE. Once gas is ignited, turn the knob to adjust the flame size.

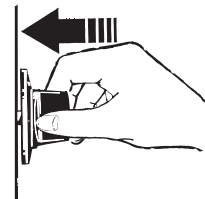

Push the control knob in and turn it to the LITE position.

Automatic Reignition

The burners on this range will automatically relight if the flame goes out.

Selecting a Flame Size

Watch the flame, not the knob, as you adjust heat. When rapid heating is desired, the flame size should match the size of the cookware you are using. Flames larger than the bottom of the cookware will not heat faster and may be hazardous.

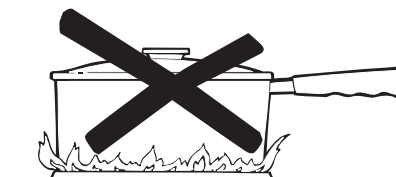

These flames are too large for the pot

Using the Surface Burners

NOTES:

- Do not operate the burner for an extended period of time without cookware on the grate. The finish on the grate may discolor or chip without cookware to absorb the heat.
- Do not attempt to disassemble any burner while another burner is on. Damage to the product may occur.
- Be sure the burners and grates are cool before you place your hand, a pot holder or cleaning materials on them.

Your rangetop has sealed gas burners that offer convenience, cleanability and flexibility for a wide range of cooking applications.

Using the Range

SURFACE BURNERS (cont.)

Types of Surface Burners

Round Burner

Use this burner for general cooking purposes. Size cookware appropriately to the flames.

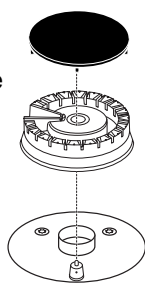

Inspiral Burner

Use this efficient inward firing burner that is ideal for medium and large cookware and wok cooking but not ideal for delicate foods.

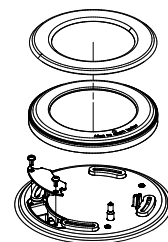

Multi-ring Burner

Use this burner for large cookware or for simmering applications.

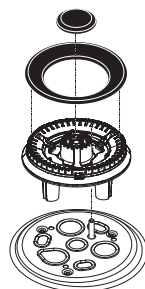

Inspiral Burner

The Inspiral burner uses an inward flame pattern delivering more even heat to the bottom of the pan as well as increased heat efficiency. Ideal for medium and large cookware and wok cooking but not ideal for simmering delicate foods.

Inspiral burners will produce the most heat when in the high position and then reduce the amount of heat as you turn to the simmer position. The burner is supplied with a copper enamel cap and an alternative black enamel cap.

Multi-Ring Burner

The Multi-Ring Burner has an inner and outer ring of flame. For large cookware, activate all rings by setting the burner between Hi and Med.

For small cookware or low heating applications, only activate the inner rings by setting the burner between Lo and Sim.

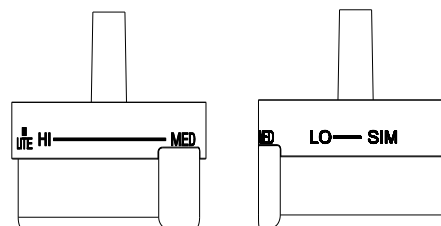

Top View Of The Multi-Ring Burner Knob

Using the Range

TOP-OF-RANGE COOKWARE

Aluminum: Medium-weight cookware is recommended because it heats quickly and evenly. Most foods brown evenly in an aluminum skillet. Use saucepans with tight-fitting lids when cooking with minimum amounts of water.

Stainless Steel: This metal alone has poor heating properties and is usually combined with copper, aluminum or other metals for improved heat distribution. Combination metal skillets usually work satisfactorily if they are used with medium heat or as the manufacturer recommends.

Cast-Iron: If heated slowly, most skillets will give satisfactory results.

Enamelware: Under some conditions, the enamel of some cookware may melt. Follow the cookware manufacturer's recommendations for cooking methods.

Glass: There are two types of glass cookware—those for oven use only and those for top-of-range cooking (saucepans, coffee and teapots). Glass conducts heat very slowly.

Heatproof Glass Ceramic: Can be used for either surface or oven cooking. It conducts heat very slowly and cools very slowly. Check the cookware manufacturer's directions to be sure it can be used on gas ranges.

WOK COOKING

⚠ WARNING Do not use a wok support ring. Placing the ring over the burner or grate may cause the burner to work improperly, resulting in carbon monoxide levels above allowable standards. This could be hazardous to your health.

The burner grate above the Inspiral burner accommodates wok sizes from 14" to 16" in diameter without the need of a separate ring. Large flat bottom pots also can use the wok grate for general cooking. This wok grate should only be located above the front right Inspiral burner.

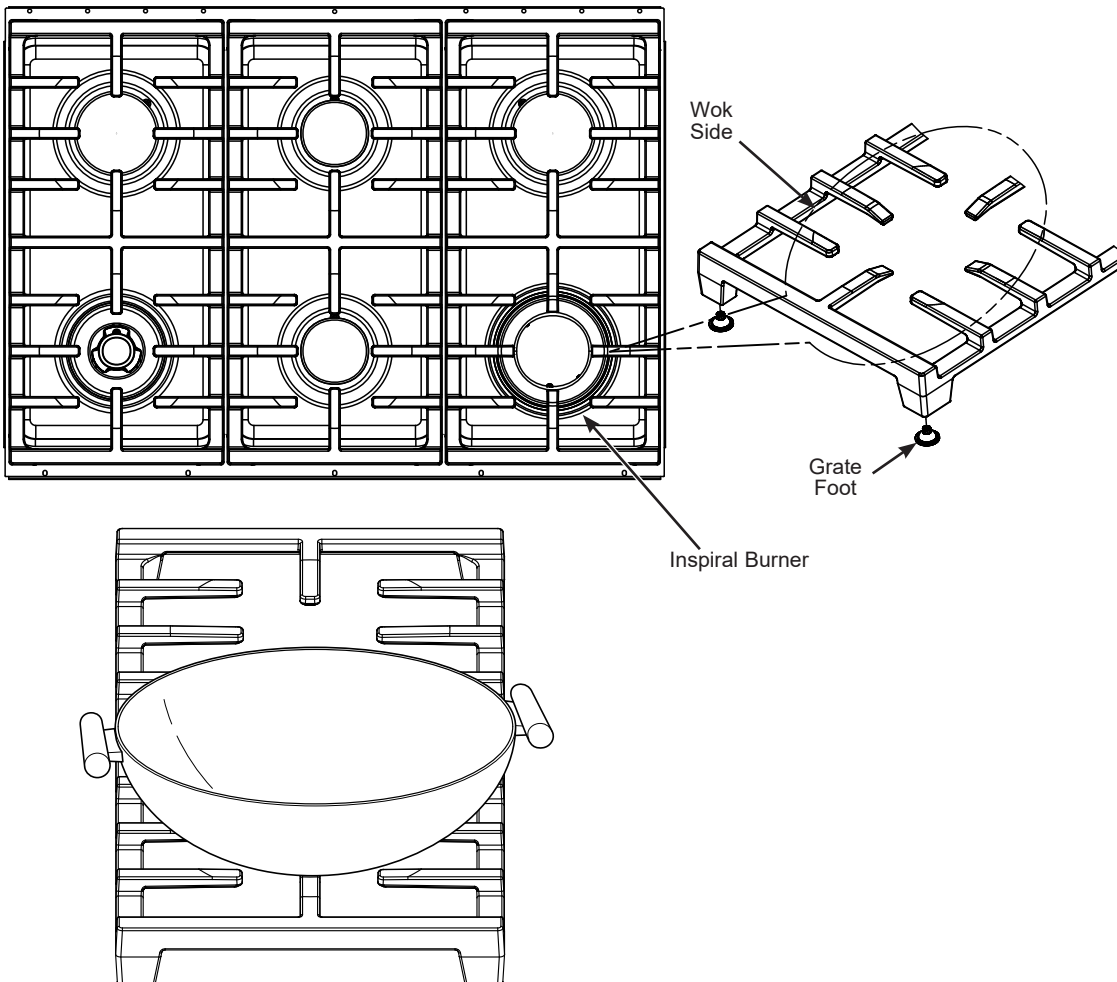

Using the Range

GRIDDLE SAFETY PRECAUTIONS, LEVELING (on some models)

▲WARNING Fire Hazard

- Use care when cooking greasy foods. Spilled grease may result in fire.
- Never place any items on the griddle when it is not in use. Heat from surrounding burners can heat the griddle and may result in fire.
- Place and remove the griddle only when griddle is cool and all surface burners are turned OFF.

Remove the metal cover before turning the griddle on.

The griddle assembly should not be removed for cleaning.

Once the unit is in position, the griddle can be leveled. Remove the flue cover by lifting it straight up. Be careful not to scratch the surrounding stainless steel surfaces during removal of the flue cover.

The two inner screws are clamping screws for securing the griddle in place. Loosen these two screws before leveling. Do not remove these two screws.

The two outer screws are leveling screws. Do not remove these two screws. They can be turned to level the griddle or to provide a forward slope to help grease and oils to drain away from the food being cooked. After the first few uses, you will be able to judge the slope best suited for the foods you are cooking and personal preference.

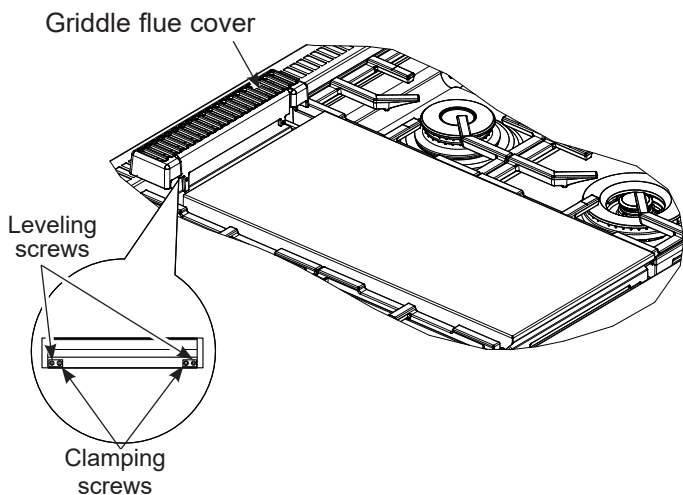

After leveling the griddle, tighten the clamping screws to secure griddle in place. Hand tighten screws; do not over-tighten.

USING THE GRIDDLE

Clean the griddle thoroughly with hot soapy water before first use and after subsequent uses. The griddle surface is made of durable, highly polished Type 304 stainless steel backed by an aluminum plate for even heat distribution. Apply a light coating of cooking oil to the griddle surface to help prevent food from sticking.

To heat the griddle, push in and turn the control knob to the desired temperature setting. The light on the bezel will glow to indicate that the thermostat control is working. The griddle is thermostatically controlled and can be set to maintain any temperature from 200°F to 450°F. Permit the griddle to preheat for 10 minutes before placing food on it.

NOTE: Unlike the surface burners which use spark igniters, the griddle uses a Glo-Bar for ignition. Gas flows to the griddle burner and ignition occurs approximately 45 seconds after the control knob is turned to a set temperature.

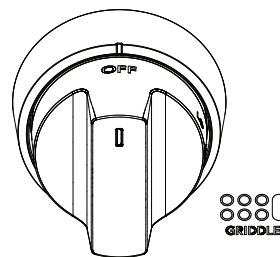

Food Item	Temperature Setting
Pancakes	375°F
Hamburgers	400°F
Bacon*	400°F
Grilled Cheese	350°F
Eggs	275°F

*NOTE: Place bacon on a cold griddle. Do not preheat.

Care And Cleaning

Be sure electrical power is off and all surfaces are cool before cleaning any part of the range

CONTROL PANEL AND KNOBS

It's a good idea to wipe the control panel after each use. Clean with mild soap and water or vinegar and water, rinse with clean water and polish dry with a soft cloth. Do not use abrasive cleansers, strong liquid cleansers, plastic scouring pads or oven cleaners on the control panel because they will damage the finish.

For easier cleaning, the control knobs may be removed by pulling them directly outwards once the knobs are in the OFF position. Do not pull knobs up or down or hang objects on them. This can damage the gas valve shaft. See the Surface Burner section for a detailed view of these knobs. The knobs can be washed by hand with soap and water.

When removing the burner knobs, remember their location. The knobs are not interchangeable, these knobs must be placed in the same location after cleaning. See the Surface Burner section for a detailed view of these knobs. To replace knobs after cleaning, align the bottom of the knob with the matching clip orientation to the shaft inside the bezel. Push knob until completely seated.

Use a soft, non abrasive cloth to clean the inside of the bezel. Do not remove diffuser film. Do not expose to moisture or it will damage lighting electronics.

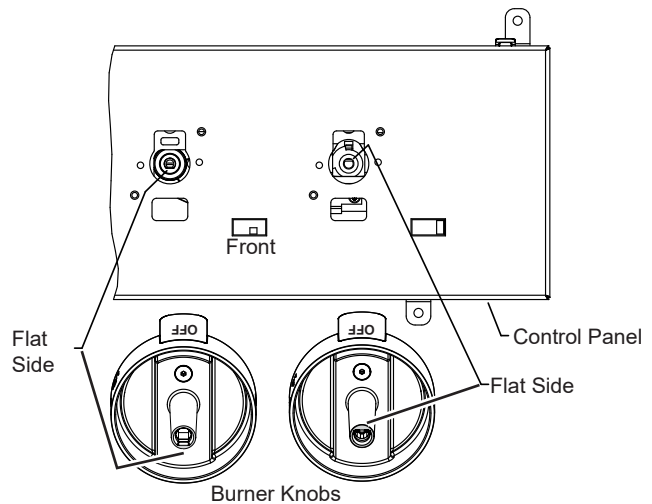

RANGETOP EXTERIOR

Do not use oven cleaners, abrasive cleansers, strong liquid cleansers, steel wool, plastic scouring pads, or cleaning powders on the cooktop surface. Clean with a mild soap and water or a 50/50 solution of vinegar and water. Rinse with clean water and dry with a soft cloth. When cleaning surfaces, make sure that they are at room temperature and not in direct sunlight.

Spillage of marinades, fruit juices, tomato sauces and basting liquids containing acids may cause discoloration and should be wiped up as soon as hot surfaces cool, Then clean and rinse.

Stainless Steel

Do not use a steel wool pad; it will scratch the surface. To clean the stainless steel surface, use warm sudsy water or a stainless steel cleaner or polish. Always wipe the surface in the direction of the grain. Follow the cleaner instructions for cleaning the stainless steel surface. Cleaners with oxalic acid such as Bar Keepers Friend Soft Cleanser™ will remove surface rust, tarnish and small blemishes. Use only a liquid cleanser free of grit and rub in the direction of the brush lines with a damp, soft sponge. To inquire about purchasing cleaning products including stainless steel appliance cleaner or polish, see the Accessories and Consumer Support sections at the end of this manual.

Care and Cleaning

ROUND, INSPIRAL, AND MULTI-RING BURNERS

CAUTION DO NOT OPERATE THE BURNER WITHOUT ALL BURNER PARTS IN PLACE.

Surface burners should be cleaned routinely, especially after bad spillovers, which could clog the slots and holes in the burner heads.

The electrode is located at the rear of each burner. Do not attempt to disassemble or clean around any burner while another burner is on. An electric shock may result.

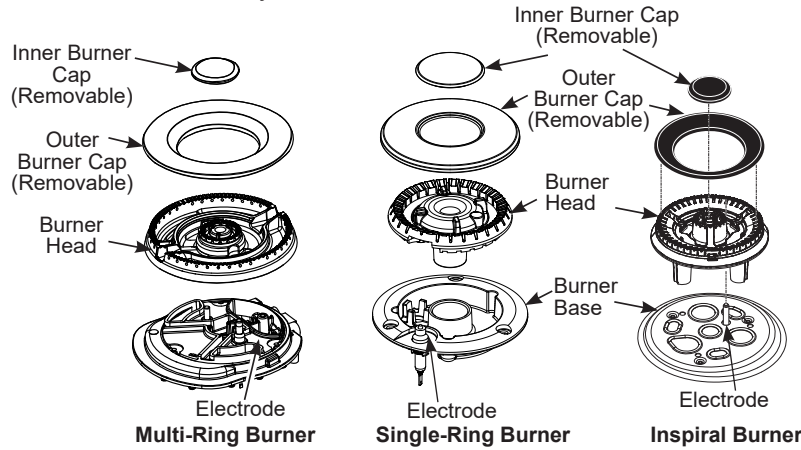

To remove the burner parts:

1. Turn all controls OFF before removing any burner parts.
2. When cool, you may lift off the burner grates, burner caps and burner heads for easier cleaning. Do not remove the burner bases.

NOTE: Be sure to replace the burners and grates in the same location and orientation.

Cleaning

Lift off burner parts only when cool. Wash in hot, soapy water.

To remove burned-on food, soak the burner heads in a solution of mild liquid detergent and hot water for 20–30 minutes. For more stubborn stains, use a plastic scouring pad or toothbrush.

If the spill goes inside the burner head assembly, wash it under running water and shake to remove excess water.

After Cleaning

Before replacing the burner parts, shake out excess water and then dry them thoroughly.

To replace the burner parts for Multi Ring:

Align the burner head as shown. Pass the igniter through the opening in the burner head while ensuring the igniter arrow is pointing toward the ignitor. Make sure the burner lies flat. Install the burner caps taking care to check that they lie flat on the burner head. Check burner operation to ensure uniform, blue flame around the burner. If there are yellow or uneven flames, immediately turn the burner off, let it cool, and readjust the burner and burner caps.

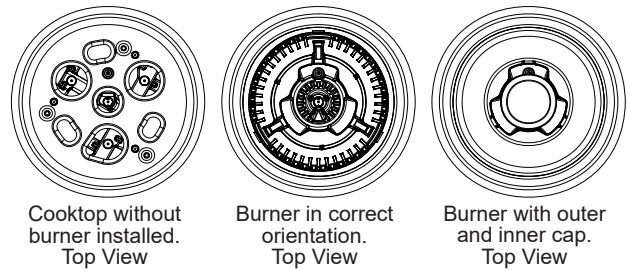

To replace the burner parts for Round Burner:

Make sure that the burner parts are replaced in the correct location and orientation.

1. Replace the burner head on top of the burner base, making sure that the hole in the burner head is properly aligned with the electrode in the burner base. A small gap between the base and head is normal.
2. Place the burner cap on top of the burner head. Make sure that the burner cap is properly seated on the burner head.

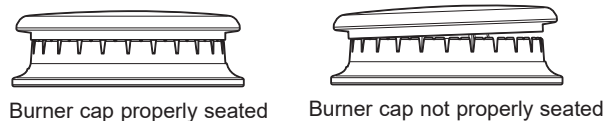

To replace the burner parts for Inspiral Burner:

Follow graphics to align spark ignitor

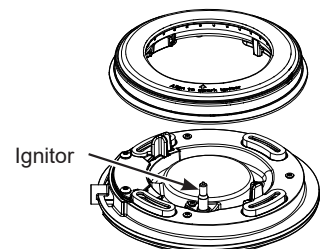

Care And Cleaning

SPARK IGNITER AND ELECTRODES

The electrode of the electronic ignition system is positioned at the rear of the burner base. When cleaning the cooktop, be careful not to snag the igniter with your cleaning cloth. Damage to the igniter could occur.

Be careful not to push in a control knob while cleaning. It could cause the igniter to spark.

Make sure that the white ceramic igniters on the cooktop are dry and clean. Clean the metal portion of the electrode with a soft cloth or emery board.

Do not attempt to remove the electrode from the cooktop.

Clean this metal part with an emery board.



Do not clean this white ceramic part with an emery board.

BURNER GRATES

The enameled cast-iron burner grates should be cleaned regularly.

Wash them in hot soapy water, rinse, and dry thoroughly.

Although they are durable, the grates will gradually lose their shine, regardless of the best care you can give them. This is due to their continual exposure to high temperatures.

Do not operate a burner for an extended period of time without cookware on the grate. The finish on the grate may chip without cookware to absorb the heat.

For stability, the frames have rubber pads on each corner. During cleaning and use, be careful not to damage or snag rubber pads.

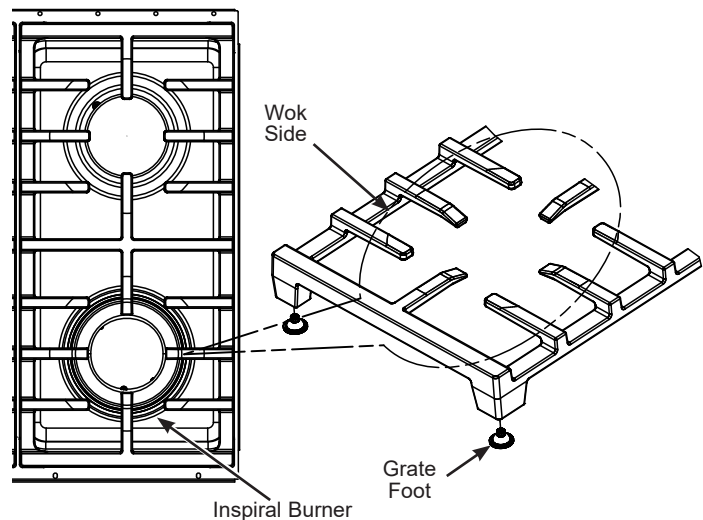

GREASE TROUGH (on some models)

Grease from the griddle will drain into the enameled cast-iron grease trough at the front of the range. Ensure grease trough is pushed underneath the griddle lip in order to catch grease while cooking. Once the trough has cooled, it may be lifted out for easier cleaning.

To remove the cool grease trough from the griddle, slide it toward the front and lift up.

Do not allow grease to accumulate in the grease trough as it can be a fire hazard. Clean the grease trough as soon as they are cool. The grease trough can be cleaned by hand with hot soapy water or in the dishwasher. Wipe any spillage in the trough basin with a soft cloth.

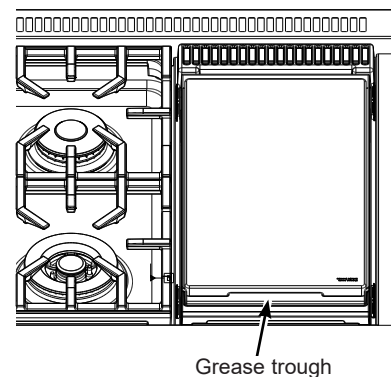

GRIDDLE (on some models)

Thoroughly clean the griddle of grease and food particles, using a square-edged metal spatula, while it is still hot.

Wipe the griddle with a dry, heavy, coarse cloth to remove any remaining residue and food particles. If the griddle is cleaned with anything other than a dry, heavy, coarse cloth, it will need to be reseasoned.

Never flood the hot griddle with cold water. This could cause the griddle to crack or warp.

NOTE: It is normal for the stainless steel griddle to discolor to a yellow-brown color after use.

Troubleshooting Tips

Save time and money! Review the charts on the following pages first and you may not need to call for service.

Problem	Possible Cause	What To Do
Burners do not light	Plug on range is not completely inserted in the electrical outlet.	Make sure electrical plug is plugged into a live, properly grounded outlet.
	Gas supply not connected or turned on.	See the Installation Instructions that came with your range.
	A fuse in your home may be blown or the circuit breaker tripped.	Replace the fuse or reset the circuit breaker.
	Burner parts not replaced correctly.	See the Care and Cleaning of the range section.
	Burner slots near the electrode may be clogged.	Remove the burners and clean them. Check the electrode area for burned-on food or grease. See the Care and Cleaning of the range section.
	Food residue on electrode	Lightly polish flat tip of electrode with nail file or sandpaper until shiny.
Top burners do not burn evenly	Improper burner assembly.	Make sure the burner caps are seated correctly. See the Care and Cleaning of the range section.
	Burner slots on the side of the burner may be clogged.	Remove the burners for cleaning. See the Care and Cleaning of the range section.
Burner flames are very large or yellow	Improper air to gas ratio.	If range is connected to Propane gas, contact the technician who installed your range or made the conversion.

Limited Warranty

cafeappliances.com

All warranty service is provided by our Factory Service Centers, or an authorized service technician. To schedule service online, visit us at cafeappliances.com/service. In Canada, visit cafeappliances.ca/service. Please have your serial number and your model number available when scheduling service.

Servicing your appliance may require the use of the onboard data port for diagnostics. This gives a Café factory service technician the ability to quickly diagnose any issues with your appliance and helps Café improve its products by providing Café with information on your appliance. If you do not want your appliance data to be sent to Café, please advise your technician not to submit the data to Café at the time of service.

For the period of	Café will replace
One year From the date of the original purchase	Any part of the cooktop which fails due to a defect in materials or workmanship. During this limited one-year warranty , Café will provide, free of charge , all labor and in-home service to replace the defective part.

What Café will not cover:

- Service trips to your home to teach you how to use the product.
- Discoloration of the oven racks.
- Chipping of porcelain enamel grates or oven racks.
- Replacement of house fuses or resetting of circuit breakers.
- Incidental or consequential damage caused by possible defects with this appliance.
- Damage after delivery.
- Damage to the product caused by accident, fire, floods or acts of God.
- Product damage or failure of the product if it is abused, misused, used for other than the intended purpose, or used commercially.
- Improper installation, delivery or maintenance. If you have an installation problem, contact your dealer or installer. You are responsible for providing adequate electrical, gas, exhausting and other connecting facilities as described in the Installation Instructions provided with the product.
- Product not accessible to provide required service.

EXCLUSION OF IMPLIED WARRANTIES

Your sole and exclusive remedy is product repair as provided in this Limited Warranty. Any implied warranties, including the implied warranties of merchantability or fitness for a particular purpose, are limited to one year or the shortest period allowed by law.

Staple your receipt here. Proof of the original purchase date is needed to obtain service under the warranty.

This limited warranty is extended to the original purchaser and any succeeding owner for products purchased for home use within the USA. If the product is located in an area where service by a Café Authorized Servicer is not available, you may be responsible for a trip charge or you may be required to bring the product to an Authorized Café Service location for service. In Alaska, the limited warranty excludes the cost of shipping or service calls to your home.

Some states do not allow the exclusion or limitation of incidental or consequential damages. This limited warranty gives you specific legal rights, and you may also have other rights which vary from state to state. To know what your legal rights are, consult your local or state consumer affairs office or your state's Attorney General.

Warrantor: GE Appliances, a Haier company
Louisville, KY 40225

Canada : MC Commercial Inc., Burlington, ON L7R 5B6

Extended Warranties: Purchase a Café extended warranty and learn about special discounts that are available while your warranty is still in effect. You can purchase it online anytime at

cafeappliances.com/extended-warranty

Café Service will still be there after your warranty expires.

Consumer Support

CAFÉ Website

Have a question or need assistance with your appliance? Try the CAFÉ website 24 hours a day, any day of the year! You can also shop for more great CAFÉ products and take advantage of all our on-line support services designed for your convenience. In the US: cafeappliances.com In Canada: cafeappliances.ca

Register Your Appliance

Register your new appliance on-line at your convenience! Timely product registration will allow for enhanced communication and prompt service under the terms of your warranty, should the need arise. You may also mail in the pre-printed registration card included in the packing material. In the US: cafeappliances.com/register
In Canada: cafeappliances.ca/registration

Schedule Service

Expert CAFÉ repair service is only one step away from your door. Get on-line and schedule your service at your convenience any day of the year. In the US: cafeappliances.com/service In Canada: cafeappliances.ca/service

Extended Warranties

Purchase a CAFÉ extended warranty and learn about special discounts that are available while your warranty is still in effect. You can purchase it on-line anytime. CAFÉ Service will still be there after your warranty expires.
In the US: cafeappliances.com/extended-warranty In Canada: cafeappliances.ca/extended-warranty

Remote Connectivity

For assistance with wireless network connectivity (for models with remote enable), visit our website at cafeappliances.com/connect In Canada: cafeappliances.ca/connect

Parts and Accessories

Individuals qualified to service their own appliances can have parts or accessories sent directly to their homes (VISA, MasterCard and Discover cards are accepted). Order on-line today 24 hours every day.
In the US: cafeappliances.com/parts

Instructions contained in this manual cover procedures to be performed by any user. Other servicing generally should be referred to qualified service personnel. Caution must be exercised, since improper servicing may cause unsafe operation.

Customers in Canada should consult the yellow pages for the nearest Mabe service center, visit our website at cafeappliances.ca/parts

Contact Us

If you are not satisfied with the service you receive from CAFÉ, contact us on our website with all the details including your phone number, or write to:

In the US: General Manager, Customer Relations | CAFÉ Appliances, Appliance Park | Louisville, KY 40225
cafeappliances.com/contact

In Canada: Director, Consumer Relations, Mabe Canada Inc. | Suite 310, 1 Factory Lane | Moncton, N.B. E1C 9M3
cafeappliances.ca/contact